

# 0.4mm Pitch, 1.5 to 4.0mm Height, Board-to-Board and Board-to-FPC Connectors

## DF40 Series

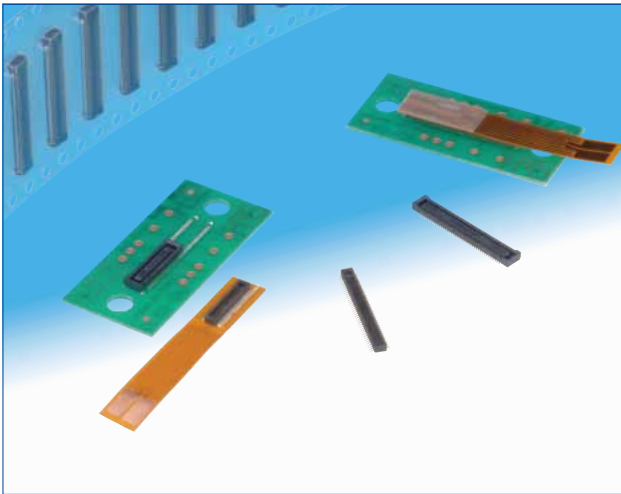

### Space saving

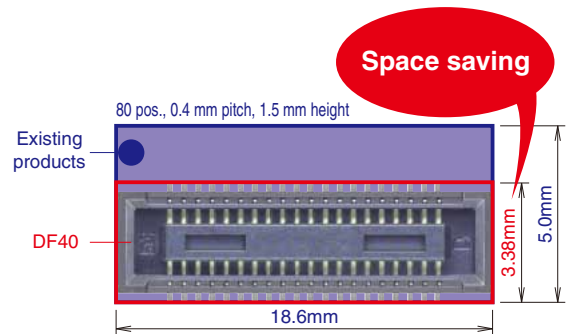

## ■ Features

### 1. High density mounting

Space saving design that has a minimum connector width, yet still retains a sufficient vacuum area for easy pick-and-place mounting  
Minimum width : 3.38mm

### 2. Multiple stack height options

In addition to its space saving design, several stack heights are available and add versatility to any application. Stack heights : 1.5mm, 2.0mm, 2.5mm, 3.0mm, 3.5mm, and 4.0mm.

### 3. High contact reliability

Despite its small stature and low profile, the contacts deliver strong contact forces and an effective mating length of 0.45mm on the 1.5mm stacking height. This connector utilizes a locking system that prevents accidental unmating issues and emits a clear tactile click to ensure that mating has been completed.

### 4. Excellent self-aligning range

The use of guide ribs allows 0.33mm of self-alignment on this connector.

### 5. Reinforced structure with shock absorbing ribs

Both sides of the connector have been reinforced with the addition of shock absorbing ribs.

### 6. Solder wicking prevention

Nickel-plated barriers were added to protect the contact areas from potential solder wicking.

### 7. Contamination resistant design

When mated, the connector's design covers the contacts which help to keep dust and other debris away from the contacts. The SMT leads are kept very close to the connector housing which also helps to prevent shorts caused by debris on the exposed contacts.

### 8. RoHS compliant

Environment friendly and does not use RoHS specified prohibited materials. All materials and substances used to produce these parts comply with the RoHS standards.

### 9. High speed signal with noise prevention

The shielded type can support high speed signal transmissions with noise prevention.

### High contact reliability - effective mating length 0.45mm

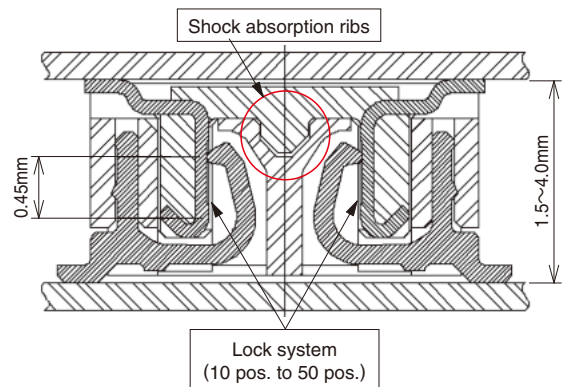

### Stacking height variations

#### Standard type

Stacking height	1.5 mm	2.0 mm	2.5 mm	3.0 mm	3.5 mm	4.0 mm
	No. of Contacts					
10	○	-	○	-	-	-
12	○	○	-	-	-	-
20	○	○	○	-	○	-
24	○	○	-	-	-	-
30	○	○	○	○	○	-
34	○	-	-	-	-	-
40	○	○	○	○	○	-
44	-	○	-	○	-	-
50	○	○	○	○	○	○
60	○	○	○	○	○	○
70	○	○	-	○	-	-
80	○	○	-	○	○	○
90	○	-	-	○	-	○
100	○	-	-	○	-	-

#### Shielded type

Stacking height	1.5 mm	3.0 mm
	No. of Contacts	
30	○	-
48	○	○
70	-	○

## Product Specifications

Ratings	Rated Current 0.3A	Operating Temperature Range -35 to +85°C (Note 1)	Storage Temperature Range -10 to +60°C (Note 2)
	Rated Voltage AC, DC 30V	Operating Humidity Range 20 to 80%	Storage Humidity Range 40 to 70% (Note 2)

Items	Specifications	Conditions
1. Insulation Resistance	50MΩ min	Measured with DC 100V
2. Withstanding Voltage	No flashover or breakdown	Apply AC 100V for 1 minute
3. Contact Resistance	90mΩ max	Measured with AC 20mV, 1 kHz and 1mA
4. Vibration Resistance	No electrical discontinuity of 1μs or greater	Frequency 10-55 Hz, half amplitude 0.75mm, 3 directions for 2 hours
5. Humidity Resistance	Contact resistance : 90mΩ max Insulation resistance : 25mΩ min	Left at temperature 40 ± 2°C, humidity 90 to 95%, 96 hours
6. Temperature Cycles	Contact resistance : 90mΩ max Insulation resistance : 50mΩ min	(-55°C : 30 minutes → 5~35°C : 10 minutes → 85°C : 30 minutes → 5~35°C : 10 minutes) 5 cycles
7. Durability	Contact resistance : 90mΩ max	30 mating cycles
8. Soldering Heat Resistance	Should be no melting of resin parts that affects its performance	Reflow : according to the Recommended Temperature Profile Hand solder : Soldering iron temperature 350°C, no more than 3 seconds.

Note 1 : Includes temperature rise caused by current flow.

Note 2 : The term "storage" here refers to products stored for a long period prior to board mounting and use. The operating temperature and humidity range covers the non-energized condition of connectors after board mounting and the temporary storage conditions during transportation, etc.

## Materials (Standard, non shielded type) / Finish

Product	Component	Materials	Finish	UL Regulation
Receptacle	Insulator	LCP	Black	UL94V-0
	Contact	Phosphor bronze	Gold plating	————
Header	Insulator	LCP	Black	UL94V-0
	Contact	Phosphor bronze	Gold plating	————

## Materials (Shielded type) / Finish

Product	Component	Materials	Finish	UL Regulation
Receptacle	Insulator	LCP	Black	UL94V-0
	Contact	Phosphor bronze	Gold plating	————
	Shield plate			————
Header	Insulator	LCP	Black	UL94V-0
	Contact	Phosphor bronze	Gold plating	————
	Reinforcing metal fitting			————

## Product Number Structure (Standard, non-shielded type)

Refer to the chart below when determining the product specifications from the product number.  
Please select from the product numbers listed in this catalog when placing orders.

### ●Receptacle

**DF40** **#** - **(\*\*)** - **\*** **DS** - **0.4** **V** **(\*\*)**

①      ②      ③      ④      ⑤      ⑥      ⑦      ⑧

① Series Name: DF40	③ Stacking height	④ No. of Contacts
② Style B : With reinforcing metal fitting HB : With reinforcing metal fitting (The H denotes a stacking height 2.5mm or above) C : Without reinforcing metal fitting HC : Without reinforcing metal fitting (The H denotes a stacking height 2.5mm or above)	Display	Stacking height
	None	1.5mm
	2.0	2.0mm
	2.5	2.5mm
	3.0	3.0mm
	3.5	3.5mm
	4.0	4.0mm
		⑤ Connector Type DS : Double row receptacle
		⑥ Contact Pitch : 0.4mm
		⑦ Mating direction Shape V : Vertical SMT
		⑧ Packaging Type (51) Embossed tape packaging

### ●Header

**DF40** **#** - **\*** **DP** - **0.4** **V** **(\*\*)**

①      ②      ③      ④      ⑤      ⑥      ⑦

① Series Name : DF40	③ No. of Contacts	⑤ Contact Pitch : 0.4mm
② Style C : Without reinforcing metal fitting	④ Connector Type DP : Double row pin header	⑥ Mating direction V : Vertical SMT
		⑦ Packaging Type (51) Embossed tape packaging

## Shielded type

### ●Receptacle

**DF40** **GB** - **(\*\*)** - **\*** **DS** - **0.4** **V** **(\*\*)**

①      ②      ③      ④      ⑤      ⑥      ⑦      ⑧

① Series Name : DF40	③ Stacking height	⑤ Connector Type DS : Double row receptacle
② Style GB : With shield	Display	Stacking height
	1.5	1.5mm
	3.0	3.0mm
	④ No. of Contacts	⑥ Contact Pitch : 0.4mm
		⑦ Mating direction V : Vertical SMT
		⑧ Packaging Type (51) Embossed tape packaging

### ●Header

**DF40** **GB** - **\*** **DP** - **0.4** **V** **(\*\*)**

①      ②      ③      ④      ⑤      ⑥      ⑦

① Series Name : DF40	③ No. of Contacts	⑤ Contact Pitch : 0.4mm
② Style GB : With reinforcing metal fitting (For use with shielded product)	④ Connector Type DP : Double row pin header	⑥ Mating direction V : Vertical SMT
		⑦ Packaging Type (51) Embossed tape packaging

## ■ Receptacle (Stacking height 1.5mm)

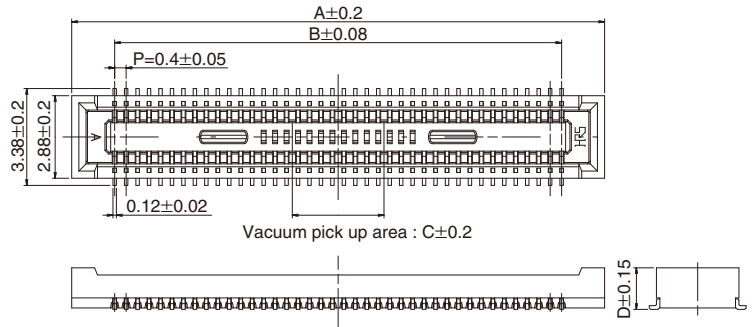
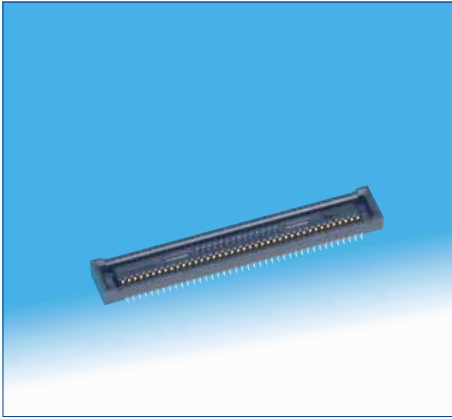

## ◆ Recommended PCB layout

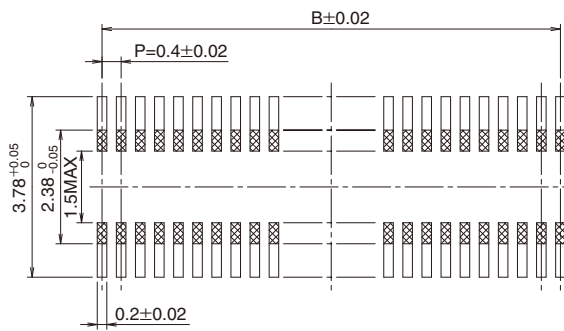

DF40C(Without reinforcing metal fitting)

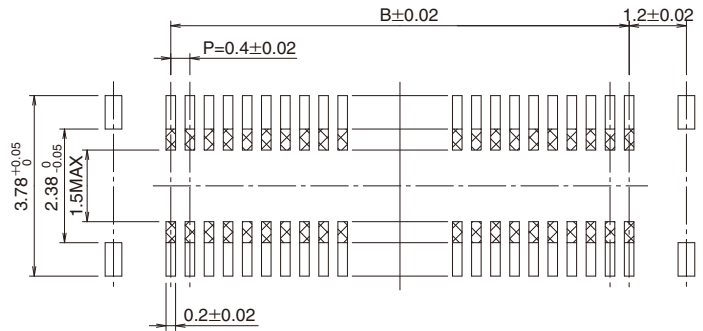

DF40B(With reinforcing metal fitting)

## ■ Stacking height 1.5mm

【Specification No.】  
(51) : Embossed package 5,000 pcs/reel

Unit : mm						
Part No.	HRS No.	No. of Contacts	A	B	C	D
DF40B-10DS-0.4V(51)	684-4038-8 51	10	4.6	1.6	1.0	1.45
DF40B-12DS-0.4V(51)	684-4152-3 51	12	5.0	2.0		
DF40B-30DS-0.4V(51)	684-4090-8 51	30	8.6	5.6		
DF40B-50DS-0.4V(51)	684-4018-0 51	50	12.6	9.6	3.2	
DF40B-60DS-0.4V(51)	684-4049-4 51	60	14.6	11.6		
DF40B-80DS-0.4V(51)	684-4052-9 51	80	18.6	15.6		
DF40C-20DS-0.4V(51)	684-4005-9 51	20	6.6	3.6	1.0	
DF40C-24DS-0.4V(51)	684-4006-1 51	24	7.4	4.4	1.2	
DF40C-30DS-0.4V(51)	684-4007-4 51	30	8.6	5.6	1.5	
DF40C-34DS-0.4V(51)	684-4023-0 51	34	9.4	6.4	2.3	
DF40C-40DS-0.4V(51)	684-4008-7 51	40	10.6	7.6	3.2	
DF40C-50DS-0.4V(51)	684-4009-0 51	50	12.6	9.6		
DF40C-60DS-0.4V(51)	684-4004-6 51	60	14.6	11.6		
DF40C-70DS-0.4V(51)	684-4016-5 51	70	16.6	13.6		
DF40C-80DS-0.4V(51)	684-4002-0 51	80	18.6	15.6		
DF40C-90DS-0.4V(51)	684-4124-8 51	90	20.6	17.6		
DF40C-100DS-0.4V(51)	684-4033-4 51	100	22.6	19.6		

Note 1 : Please place orders by full reel.

Note 2 : The surface of the 60 to 100 pos. parts have a small, concave section that will not affect the vacuum pick up operation.

Note 3 : Resist coating area.

Note 4 : This connector is NOT polarized.

## ■Receptacle (Stacking height 2.0mm)

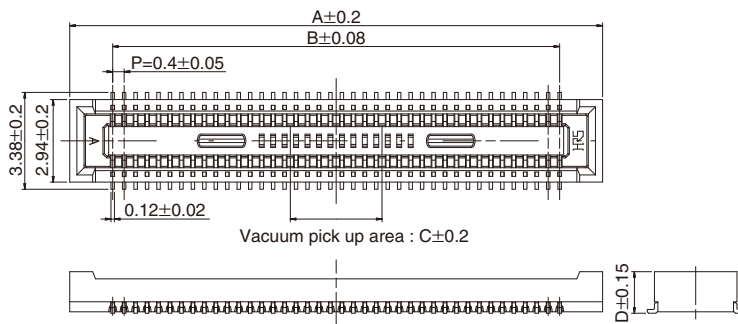

## ◆Recommended PCB layout

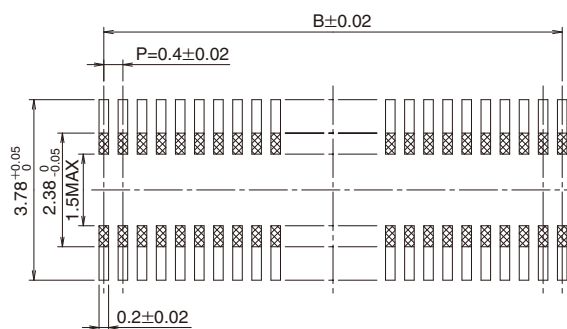

DF40C(Without reinforcing metal fitting)

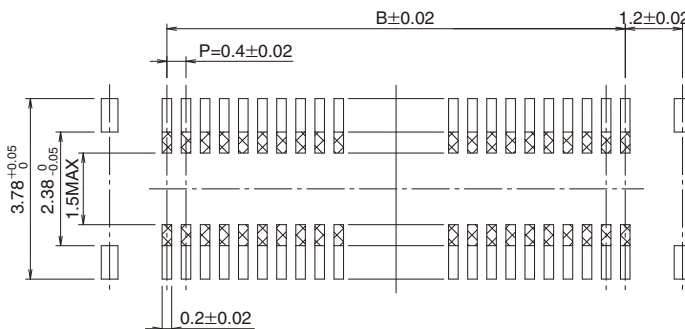

DF40B(With reinforcing metal fitting)

## ■Stacking height 2.0mm

【Specification No.】  
(51) : Embossed package 4,000 pcs/reel

Unit : mm

Part No.	HRS No.	No. of Contacts	A	B	C	D
DF40B(2.0)-12DS-0.4V(51)	684-4150-8 51	12	5.0	2.0	1.0	1.95
DF40B(2.0)-80DS-0.4V(51)	684-4128-9 51	80	18.6	15.6	3.2	
DF40C(2.0)-20DS-0.4V(51)	684-4040-0 51	20	6.6	3.6	1.0	
DF40C(2.0)-24DS-0.4V(51)	684-4021-2 51	24	7.4	4.4	1.2	
DF40C(2.0)-30DS-0.4V(51)	684-4058-5 51	30	8.6	5.6	1.5	
DF40C(2.0)-40DS-0.4V(51)	684-4042-5 51	40	10.6	7.6	3.2	
DF40C(2.0)-50DS-0.4V(51)	684-4091-0 51	50	12.6	9.6		
DF40C(2.0)-60DS-0.4V(51)	684-4034-7 51	60	14.6	11.6		
DF40C(2.0)-70DS-0.4V(51)	684-4147-3 51	70	16.6	13.6		
DF40C(2.0)-80DS-0.4V(51)	684-4132-6 51	80	18.6	15.6		

Note 1 : Please place orders by full reel.

Note 2 : The surface of the 60 to 100 pos. parts have a small, concave section that will not affect the vacuum pick up operation.

Note 3 : Resist coating area.

Note 4 : This connector is NOT polarized.

## ■ Receptacle (Stacking height 2.5mm to 4.0mm)

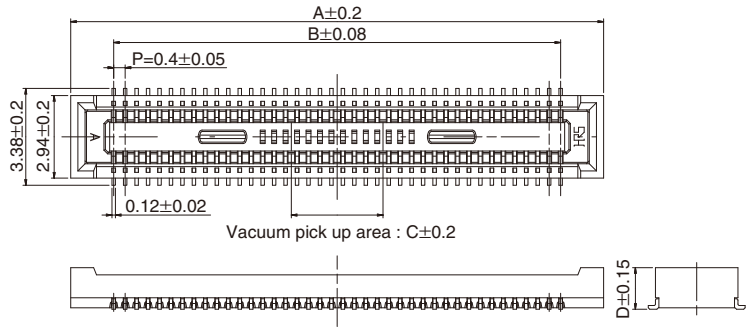
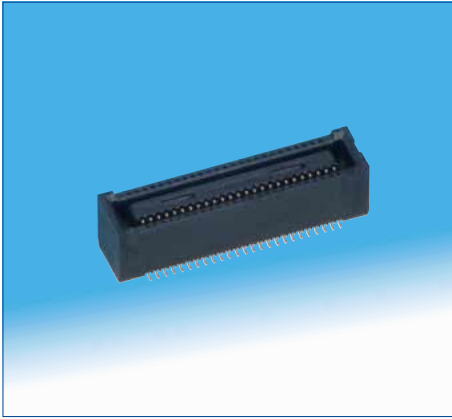

## ◆ Recommended PCB layout

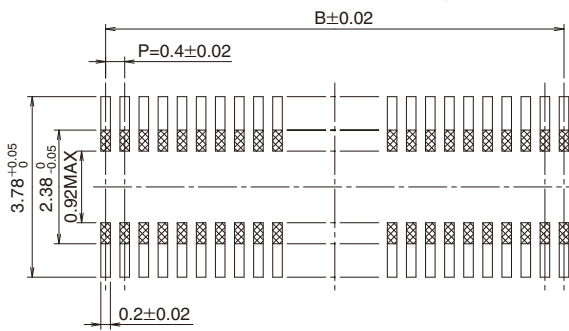

DF40HC(Without reinforcing metal fitting)

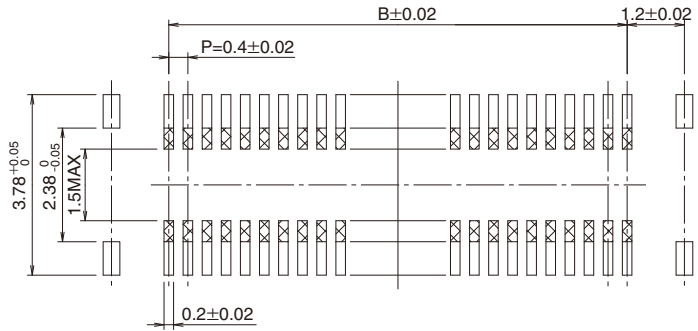

DF40HB(With reinforcing metal fitting)

## ■ Stacking height 2.5mm

【Specification No.】  
(51) : Embossed package 3,000 pcs/reel

Unit : mm

Part No.	HRS No.	No. of Contacts	A	B	C	D
DF40HB(2.5)-10DS-0.4V(51)	684-4189-3 51	10	4.6	1.6	1.0	2.4
DF40HC(2.5)-20DS-0.4V(51)	684-4126-3 51	20	6.6	3.6		
DF40HC(2.5)-40DS-0.4V(51)	684-4112-9 51	40	10.6	7.6	3.2	
DF40HC(2.5)-50DS-0.4V(51)	684-4101-2 51	50	12.6	9.6		
DF40HC(2.5)-60DS-0.4V(51)	684-4085-8 51	60	14.6	11.6		

## ■ Stacking height 3.0mm

【Specification No.】  
(51) : Embossed package 3,000 pcs/reel

Unit : mm

Part No.	HRS No.	No. of Contacts	A	B	C	D
DF40HC(3.0)-30DS-0.4V(51)	684-4098-0 51	30	8.6	5.6	1.5	2.9
DF40HC(3.0)-40DS-0.4V(51)	684-4169-6 51	40	10.6	7.6		
DF40HC(3.0)-44DS-0.4V(51)	684-4076-7 51	44	11.4	8.4	3.2	
DF40HC(3.0)-50DS-0.4V(51)	684-4099-2 51	50	12.6	9.6		
DF40HC(3.0)-60DS-0.4V(51)	684-4100-0 51	60	14.6	11.6		
DF40HC(3.0)-70DS-0.4V(51)	684-4138-2 51	70	16.6	13.6		
DF40HC(3.0)-80DS-0.4V(51)	684-4180-9 51	80	18.6	15.6		
DF40HC(3.0)-90DS-0.4V(51)	684-4161-4 51	90	20.6	17.6		
DF40HC(3.0)-100DS-0.4V(51)	684-4151-0 51	100	22.6	19.6		

Note 1 : Please place orders by full reel.

Note 2 : The surface of the 60 to 100 pos. parts have a small, concave section that will not affect the vacuum pick up operation.

Note 3 : Resist coating area.

Note 4 : This connector is NOT polarized.

## ■ Stacking height 3.5mm

【Specification No.】  
(51) : Embossed package 2,000 pcs/reel

Unit : mm

Part No.	HRS No.	No. of Contacts	A	B	C	D
DF40HC(3.5)-20DS-0.4V(51)	684-4188-0 51	20	6.6	3.6	1.0	3.4
DF40HC(3.5)-30DS-0.4V(51)	684-4136-7 51	30	8.6	5.6	1.5	
DF40HC(3.5)-40DS-0.4V(51)	684-4209-9 51	40	10.6	7.6	3.2	
DF40HC(3.5)-50DS-0.4V(51)	684-4109-4 51	50	12.6	9.6		
DF40HC(3.5)-60DS-0.4V(51)	684-4102-5 51	60	14.6	11.6		
DF40HC(3.5)-80DS-0.4V(51)	684-4162-7 51	80	18.6	15.6		

## ■ Stacking height 4.0mm

【Specification No.】  
(51) : Embossed package 2,000 pcs/reel

Unit : mm

Part No.	HRS No.	No. of Contacts	A	B	C	D
DF40HB(4.0)-50DS-0.4V(51)	684-4104-0 51	50	12.6	9.6	3.2	3.9
DF40HC(4.0)-50DS-0.4V(51)	684-4215-1 51	50	12.6			
DF40HC(4.0)-60DS-0.4V(51)	684-4133-9 51	60	14.6	11.6		
DF40HC(4.0)-80DS-0.4V(51)	684-4140-4 51	80	18.6	15.6		
DF40HC(4.0)-90DS-0.4V(51)	684-4165-5 51	90	20.6	17.6		

Note 1 : Please place orders by full reel.

Note 2 : The surface of the 60 to 100 pos. parts have a small, concave section that will not affect the vacuum pick up operation.

Note 3 :  Resist coating area.

Note 4 : This connector is NOT polarized.

## ■ Receptacle (Stacking height 1.5mm, with shield)



< 30 contact >

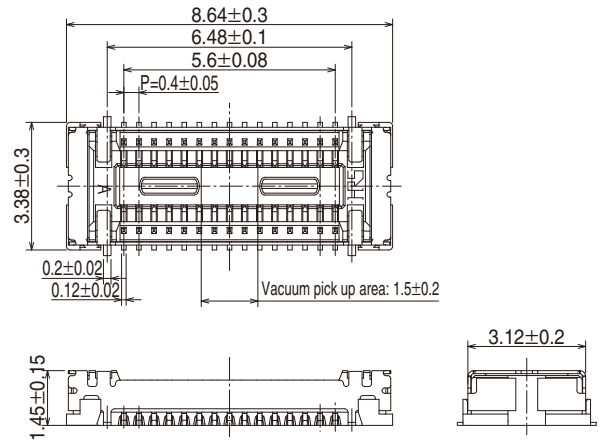

< 48 contact >

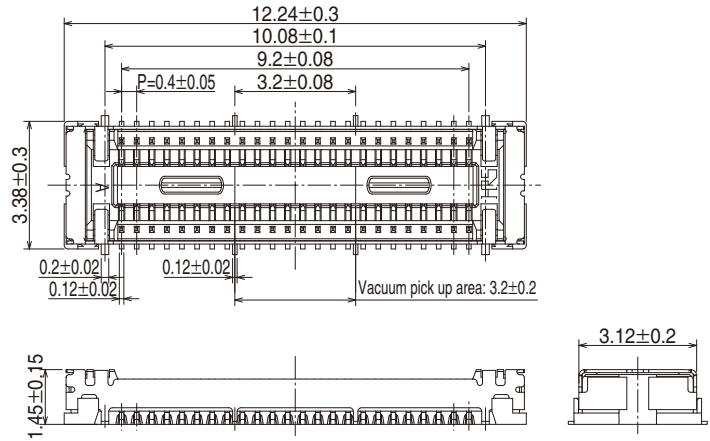

## ◆ Recommended PCB layout

< 30 contact >

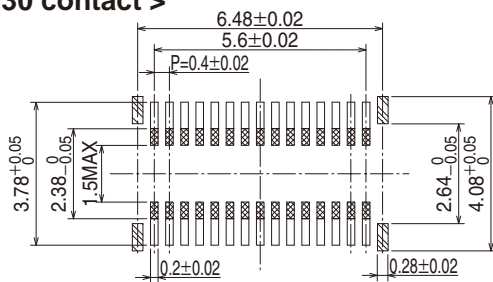

< 48 contact >

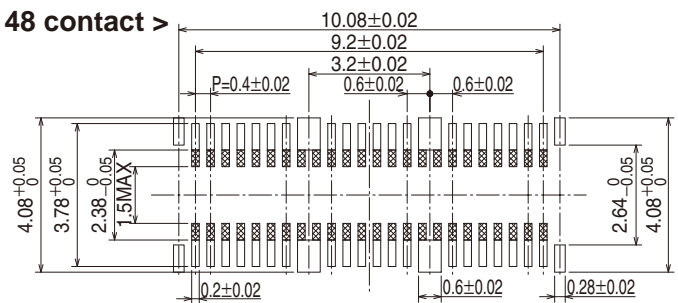

## ■ Stacking height 1.5mm

【Specification No.】  
(51) : Embossed package 5,000 pcs/reel

Unit : mm

Part No.	HRS No.	No. of Contacts	Signal contact	Ground contact
DF40GB(1.5)-30DS-0.4V(51)	684-4198-4 51	30	30	4
DF40GB(1.5)-48DS-0.4V(51)	684-4194-3 51	48	40	12

Note 1 : Please place orders by full reel.

Note 2 : Resist coating area.

Note 3 : This connector is NOT polarized.

## ■ Receptacle (Stacking height 3.0mm, with shield)



< 48 contact >

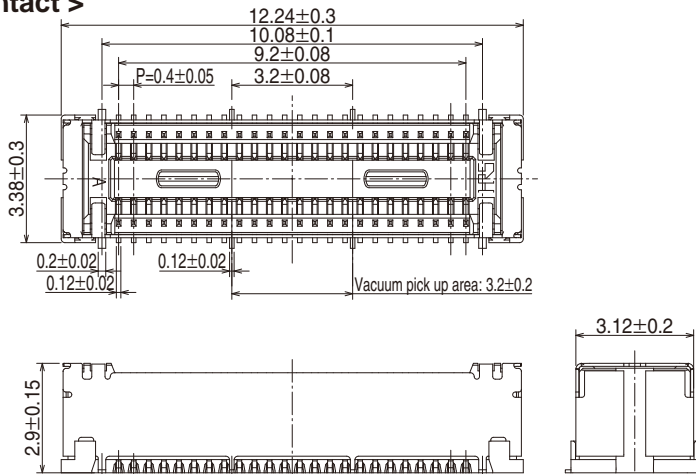

< 70 contact >

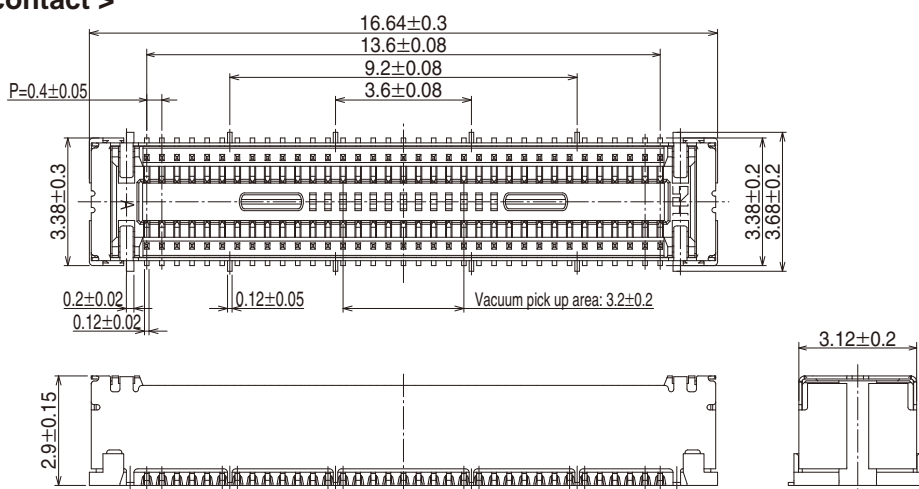

## ◆ Recommended PCB layout

< 48 contact >

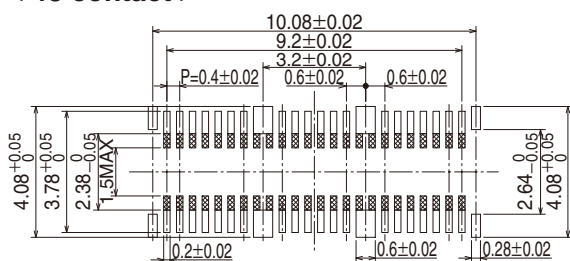

< 70 contact >

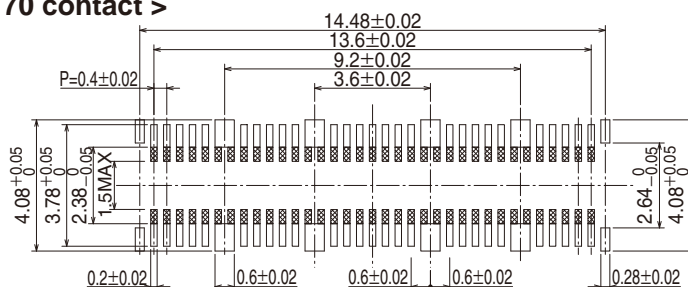

## ■ Stacking height 3.0mm

【Specification No.】  
(51) : Embossed package 3,000 pcs/reel

Unit : mm

Part No.	HRS No.	No. of Contacts	Signal contact	Ground contact
DF40GB(3.0)-48DS-0.4V(51)	684-4197-1 51	48	40	12
DF40GB(3.0)-70DS-0.4V(51)	684-4196-9 51	70	54	20

Note 1 : Please place orders by full reel.

Note 2 : The surface of the 70 pos. part have a small, concave section that will not affect the vacuum pick up operation.

Note 3 : Resist coating area.

Note 4 : This connector is NOT polarized.

## Header

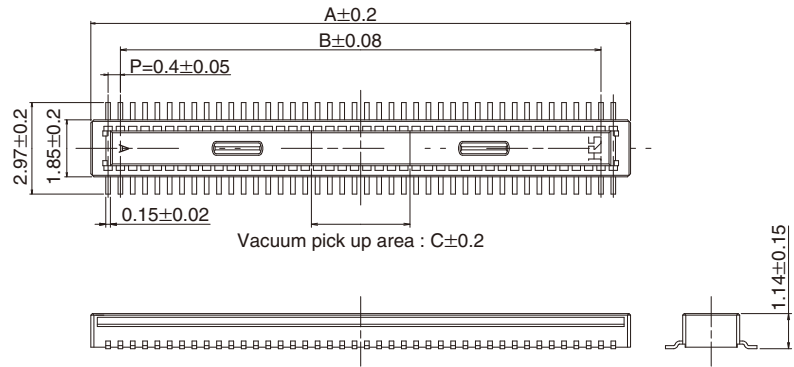
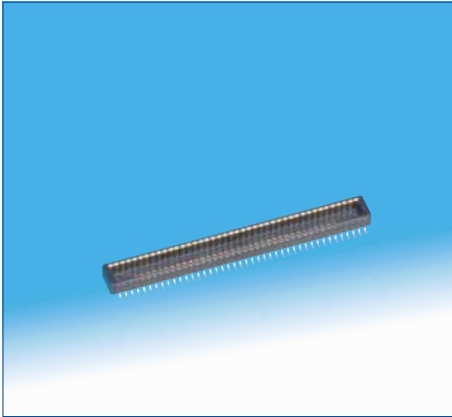

## Recommended PCB layout

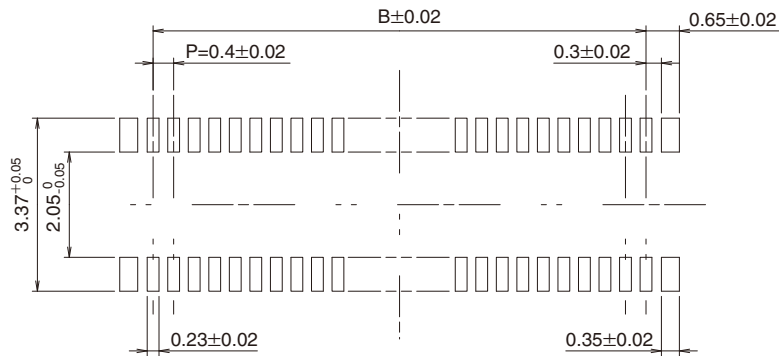

Unit : mm

Part No.	HRS No.	No. of Contacts	A	B	C
DF40C-10DP-0.4V(51)	684-4035-0 51	10	3.52	1.6	1.0
DF40C-12DP-0.4V(51)	684-4149-9 51	12	3.92	2.0	
DF40C-20DP-0.4V(51)	684-4010-9 51	20	5.52	3.6	
DF40C-24DP-0.4V(51)	684-4011-1 51	24	6.32	4.4	1.2
DF40C-30DP-0.4V(51)	684-4012-4 51	30	7.52	5.6	1.5
DF40C-34DP-0.4V(51)	684-4024-3 51	34	8.32	6.4	2.3
DF40C-40DP-0.4V(51)	684-4013-7 51	40	9.52	7.6	3.2
DF40C-44DP-0.4V(51)	684-4077-0 51	44	10.32	8.4	
DF40C-50DP-0.4V(51)	684-4014-0 51	50	11.52	9.6	
DF40C-60DP-0.4V(51)	684-4003-3 51	60	13.52	11.6	
DF40C-70DP-0.4V(51)	684-4015-2 51	70	15.52	13.6	
DF40C-80DP-0.4V(51)	684-4001-8 51	80	17.52	15.6	
DF40C-90DP-0.4V(51)	684-4125-0 51	90	19.52	17.6	
DF40C-100DP-0.4V(51)	684-4032-1 51	100	21.52	19.6	

Note 1 : Please place orders by full reel.

Note 2 : There are no concave parts on the header side contact part to increase the mating strength for 60 pos. or above.

Note 3 : Use the contacts at the four corners as metal fittings. Do not use them as signal or power contacts.

Note 4 : The surface of the 90 pos and higher parts have a small, concave section that will not affect the vacuum pick up operation.

Note 5 : This connector is NOT polarized.

## ■Header (For use with shielded product)

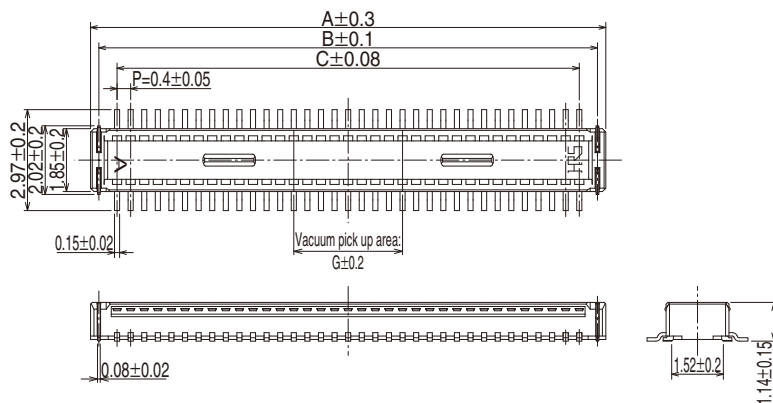

## ◆Recommended PCB layout

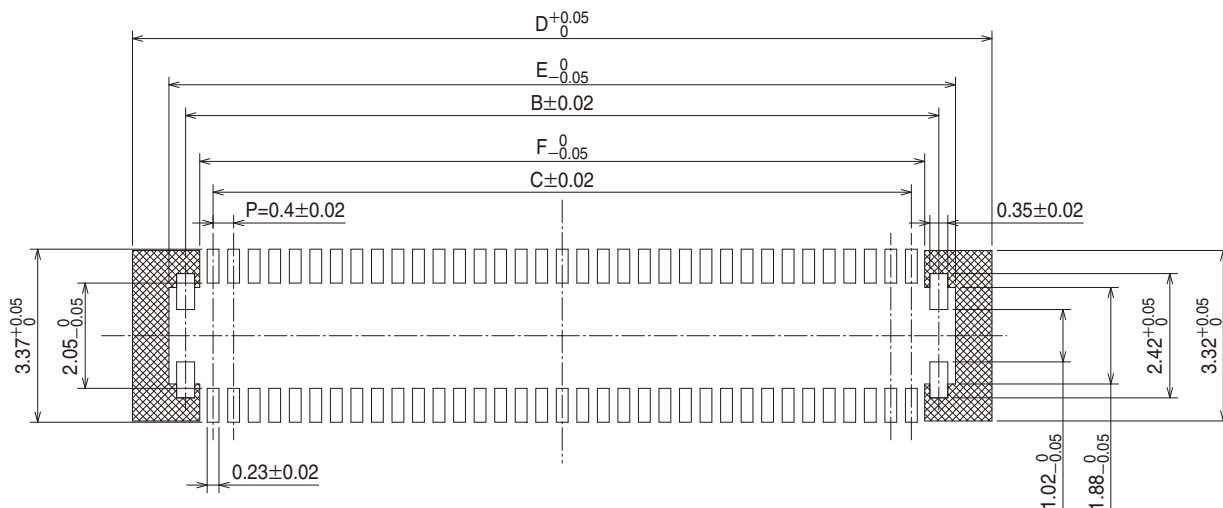

Unit : mm

Part No.	HRS No.	No. of Contacts	A	B	C	D	E	F	G
DF40GB-30DP-0.4V(51)	684-4200-4 51	30	7.16	6.67	5.6	8.74	7.32	6.12	1.5
DF40GB-48DP-0.4V(51)	684-4195-6 51	48	10.76	10.27	9.2	12.34	10.92	9.72	3.2
DF40GB-70DP-0.4V(51)	684-4199-7 51	70	15.16	14.67	13.6	16.74	15.32	14.12	3.2

Note 1 : Please place orders by full reel.

Note 2 : There are no concave parts of header side contact part to increase the mating strength for 60 pos. or above.

Note 3 : Resist coating area.

Note 4 : This connector is NOT polarized.

## ◆ Embossed Carrier Tape Dimensions (JIS C 0806 compliant)

### ● Receptacle (Stacking height 1.5mm)

### ● Reel Condition Dimensions

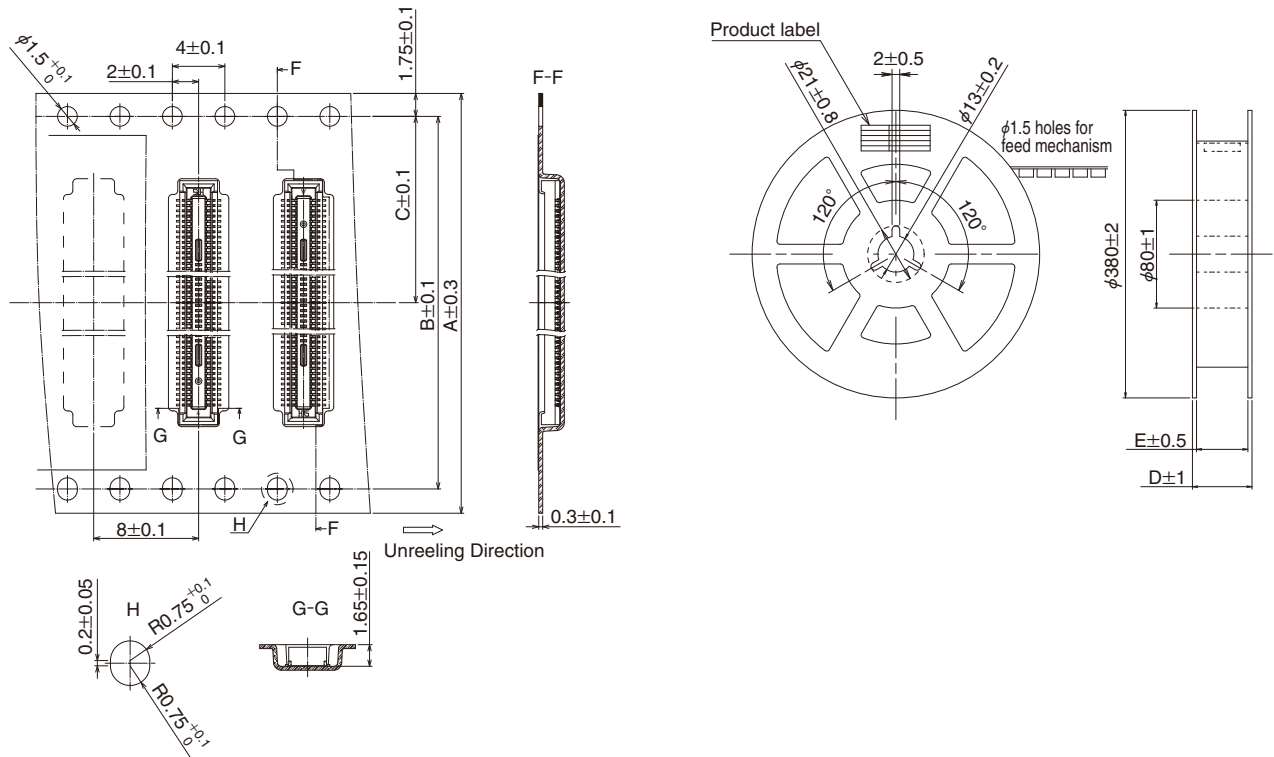

## ■ Stacking height 1.5mm

Unit : mm

Part No.	A	B	C	D	E
DF40#-10DS-0.4V(51)	16	—	7.5	21.5	17.5
DF40#-12DS-0.4V(51)		—			
DF40#-20DS-0.4V(51)		—			
DF40#-24DS-0.4V(51)		—			
DF40#-30DS-0.4V(51)	24	—	11.5	29.5	25.5
DF40#-34DS-0.4V(51)		—			
DF40#-40DS-0.4V(51)		—			
DF40#-50DS-0.4V(51)		—			
DF40#-60DS-0.4V(51)	32	—	14.2	37.5	33.5
DF40#-70DS-0.4V(51)		28.4			
DF40#-80DS-0.4V(51)		—			
DF40#-90DS-0.4V(51)		—			
DF40#-100DS-0.4V(51)	44	40.4	20.2	49.5	45.5
DF40GB(1.5)-30DS-0.4V(51)	24	—	11.5	29.5	25.5
DF40GB(1.5)-48DS-0.4V(51)		—			

Note 1 : For 10 to 60 contact position parts, the carrier tape only has one row of holes. The carrier for parts with 70 contacts and above has two rows of holes.

## ◆ Embossed Carrier Tape Dimensions (JIS C 0806 compliant)

- Receptacle (Stacking height 2.0mm to 2.5mm)
- Reel Dimensions

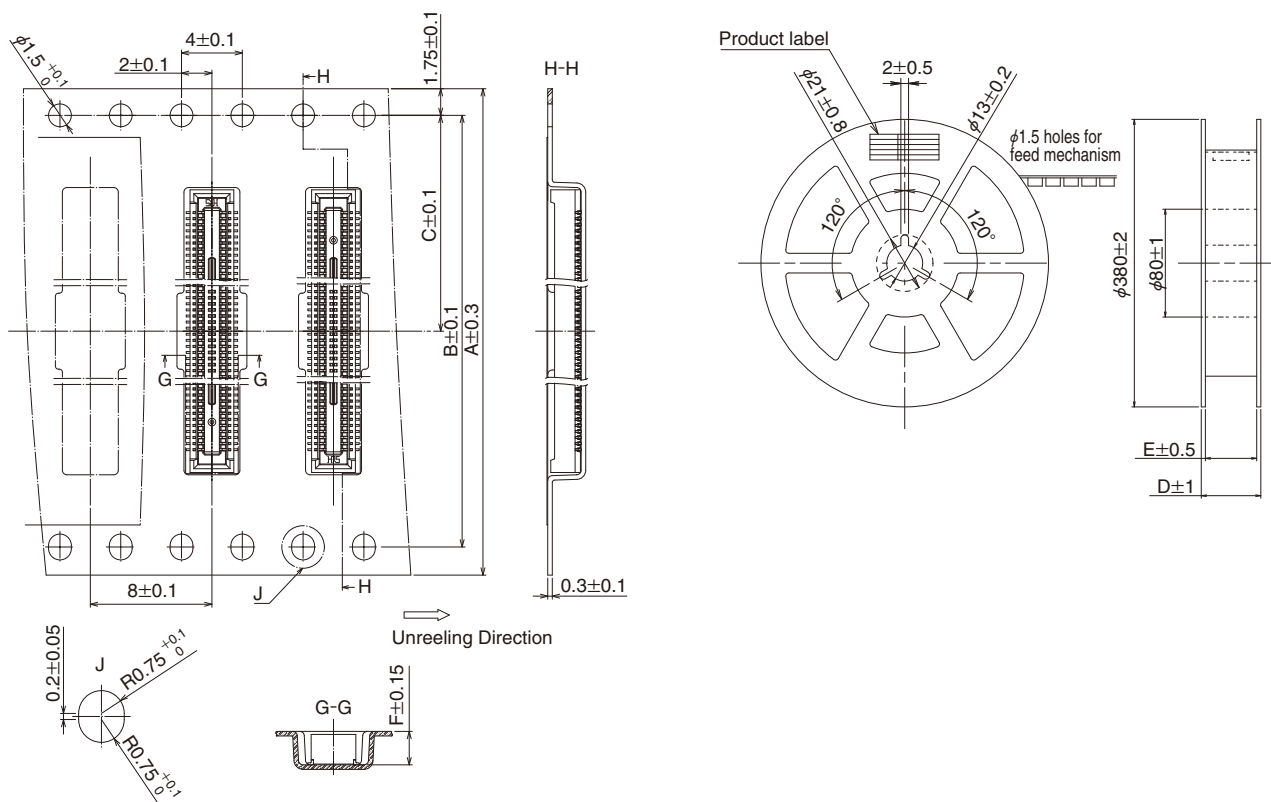

### ■ Stacking height 2.0mm

Unit : mm

Part No.	A	B	C	D	E	F
DF40#(2.0)-12DS-0.4V(51)	16	—	7.5	21.5	17.5	2.2
DF40#(2.0)-20DS-0.4V(51)		—				
DF40#(2.0)-24DS-0.4V(51)		—				
DF40#(2.0)-30DS-0.4V(51)	24	—	11.5	29.5	25.5	
DF40#(2.0)-40DS-0.4V(51)		—				
DF40#(2.0)-50DS-0.4V(51)		—				
DF40#(2.0)-60DS-0.4V(51)	32	—	14.2	37.5	33.5	
DF40#(2.0)-70DS-0.4V(51)		28.4				
DF40#(2.0)-80DS-0.4V(51)						

### ■ Stacking height 2.5mm

Unit : mm

Part No.	A	B	C	D	E	F
DF40H#(2.5)-10DS-0.4V(51)	16	—	7.5	21.5	17.5	2.72
DF40H#(2.5)-20DS-0.4V(51)		—				
DF40H#(2.5)-40DS-0.4V(51)	24	—	11.5	29.5	25.5	
DF40H#(2.5)-50DS-0.4V(51)		—				
DF40H#(2.5)-60DS-0.4V(51)		—				

Note 1 : For 10 to 60 contact position parts, the carrier tape only has one row of holes. The carrier for parts with 70 contacts and above has two rows of holes.

## ◆ Embossed Carrier Tape Dimensions (JIS C 0806 compliant)

● Receptacle (Stacking height 3.0mm to 4.0mm)

● Reel Condition Dimensions

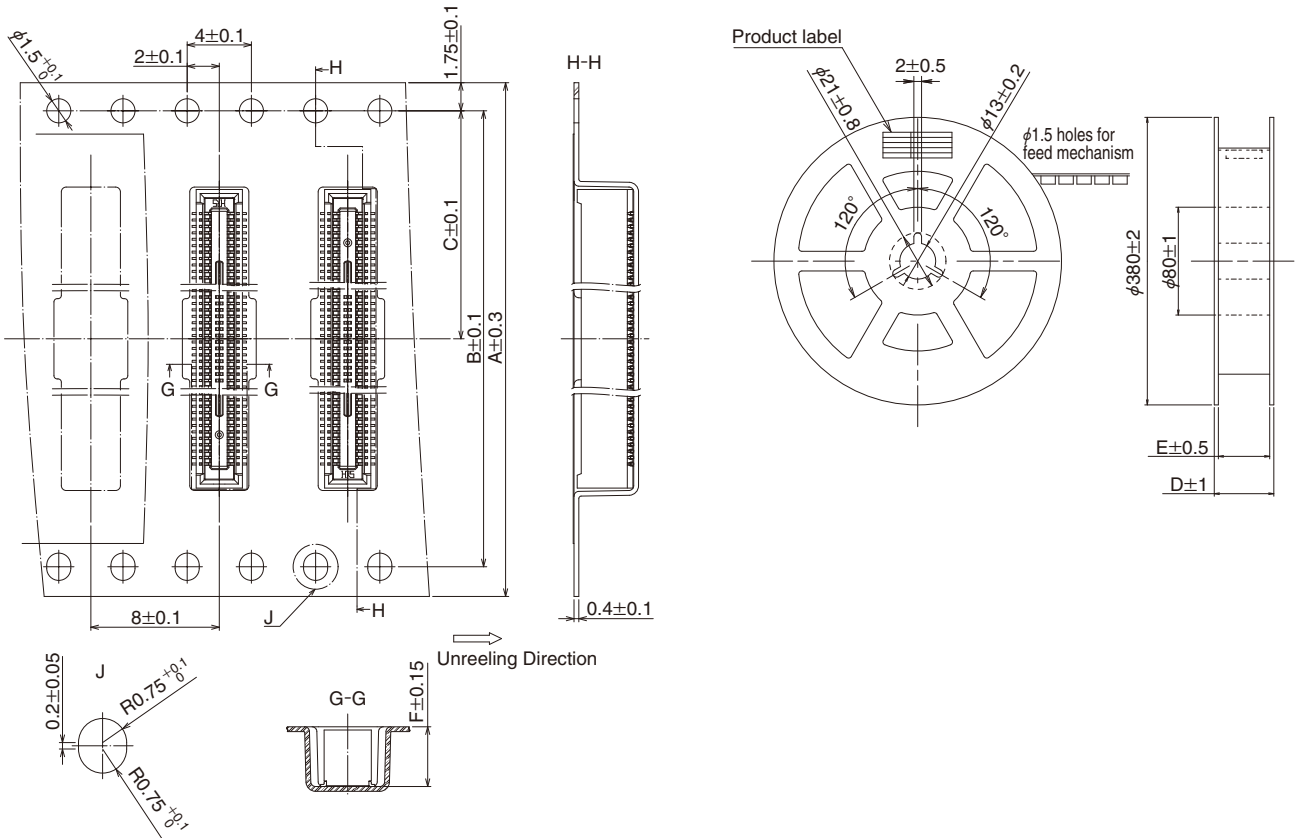

### ■ Stacking height 3.0mm

Unit : mm

Part No.	A	B	C	D	E	F
DF40H#(3.0)-30DS-0.4V(51)	24	—	11.5	29.5	25.5	3.15
DF40H#(3.0)-40DS-0.4V(51)		—				
DF40H#(3.0)-44DS-0.4V(51)		—				
DF40H#(3.0)-50DS-0.4V(51)		—				
DF40H#(3.0)-60DS-0.4V(51)		—				
DF40H#(3.0)-70DS-0.4V(51)	32	28.4	14.2	37.5	33.5	
DF40H#(3.0)-80DS-0.4V(51)	44	40.4	20.2	49.5	45.5	
DF40H#(3.0)-90DS-0.4V(51)						
DF40H#(3.0)-100DS-0.4V(51)						
DF40GB(3.0)-48DS-0.4V(51)	24	—	11.5	29.5	25.5	
DF40GB(3.0)-70DS-0.4V(51)	32	28.4	14.2	37.5	33.5	

### ■ Stacking height 3.5mm

Unit : mm

Part No.	A	B	C	D	E	F
DF40H#(3.5)-20DS-0.4V(51)	16	—	7.5	21.5	17.5	3.72
DF40H#(3.5)-30DS-0.4V(51)	24	—	11.5	29.5	25.5	
DF40H#(3.5)-40DS-0.4V(51)		—				
DF40H#(3.5)-50DS-0.4V(51)		—				
DF40H#(3.5)-60DS-0.4V(51)		—				

### ■ Stacking height 4.0mm

Unit : mm

Part No.	A	B	C	D	E	F
DF40H#(4.0)-50DS-0.4V(51)	24	—	11.5	29.5	25.5	4.15
DF40H#(4.0)-60DS-0.4V(51)		—				
DF40H#(4.0)-80DS-0.4V(51)	32	28.4	14.2	37.5	33.5	
DF40H#(4.0)-90DS-0.4V(51)	44	40.4	20.2	49.5	45.5	

Note 1 : For 10 to 60 contact position parts, the carrier tape only has one row of holes. The carrier for parts with 70 contacts and above has two rows of holes.

●Header

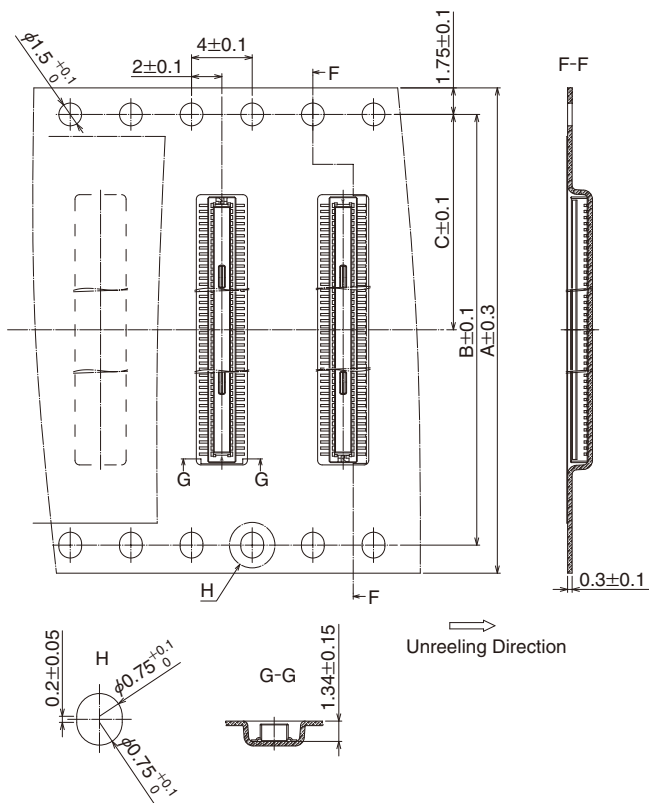

●Reel Dimensions

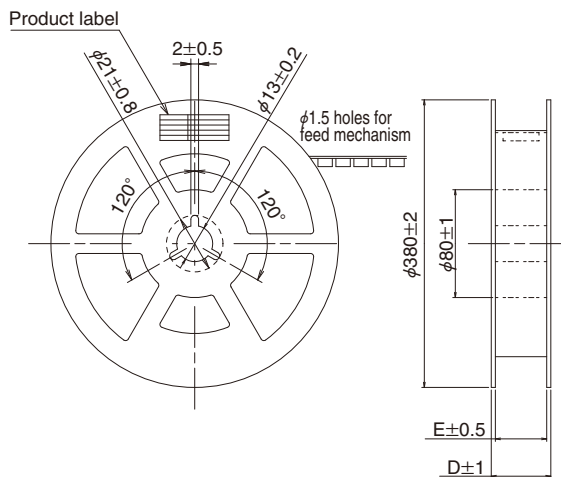

Unit : mm

Part No.	A	B	C	D	E
DF40C-10DP-0.4V(51)	12	—	5.5	17.5	13.5
DF40C-12DP-0.4V(51)		—			
DF40C-20DP-0.4V(51)	16	—	7.5	21.5	17.5
DF40C-24DP-0.4V(51)		—			
DF40C-30DP-0.4V(51)		—			
DF40C-34DP-0.4V(51)		—			
DF40C-40DP-0.4V(51)	24	—	11.5	29.5	25.5
DF40C-44DP-0.4V(51)		—			
DF40C-50DP-0.4V(51)		—			
DF40C-60DP-0.4V(51)		—			
DF40C-70DP-0.4V(51)	32	28.4	14.2	37.5	33.5
DF40C-80DP-0.4V(51)					
DF40C-90DP-0.4V(51)	44	40.4	20.2	49.5	45.5
DF40C-100DP-0.4V(51)					
DF40GB-30DP-0.4V(51)	16	—	7.5	21.5	17.5
DF40GB-48DP-0.4V(51)	24	—	11.5	29.5	25.5
DF40GB-70DP-0.4V(51)		—			

Note 1 : For 10 to 60 contact position parts, the carrier tape only has one row of holes. The carrier for parts with 70 contacts and above has two rows of holes.

## ◆ Operating Precautions

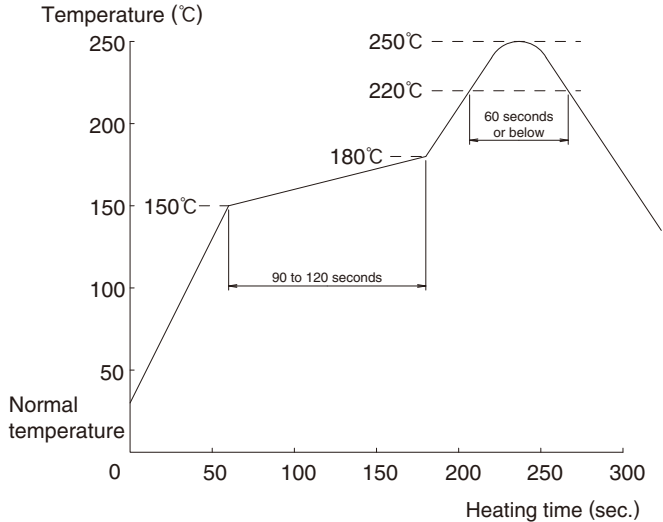
<p>1. Recommended Solder Profile</p>	 <p style="text-align: center;">Temperature (°C)</p> <p style="text-align: center;">Heating time (sec.)</p> <p><b>【Conditions】</b></p> <table border="0"> <tr> <td>1. Peak temperature</td> <td>Maximum of 250°C</td> </tr> <tr> <td>2. Heating part</td> <td>Minimum of 220°C within 60 seconds</td> </tr> <tr> <td>3. Preheating part</td> <td>150 to 180°C 90 to 120 seconds</td> </tr> <tr> <td>4. Number of times</td> <td>Maximum of 2 cycles</td> </tr> </table> <p>Note 1 : The temperature shows PCB surface temperature near the connector lead part.</p>	1. Peak temperature	Maximum of 250°C	2. Heating part	Minimum of 220°C within 60 seconds	3. Preheating part	150 to 180°C 90 to 120 seconds	4. Number of times	Maximum of 2 cycles
1. Peak temperature	Maximum of 250°C								
2. Heating part	Minimum of 220°C within 60 seconds								
3. Preheating part	150 to 180°C 90 to 120 seconds								
4. Number of times	Maximum of 2 cycles								
<p>2. Recommended hand solder conditions</p>	<p>Soldering iron temperature 340 ±10°C, solder time no more than 3 seconds</p>								
<p>3. Recommended screen thickness: Opening ratio (pattern area ratio)</p>	<p>Thickness : 0.12mm Opening ratio : DS side 80% DP side 80%</p>								
<p>4. Leaning of PCB</p>	<p>Max 0.02mm at the center of connector (using both edges of connector as criteria)</p>								
<p>5. Washing</p>	<p>Cleaning/washing is not recommended for this connector. Cleaning agents can deteriorate the mechanical operation and the environmental resistance of this connector.</p>								
<p>6. Precautions</p>	<ul style="list-style-type: none"> <li>■ Do not mate or unmate these connectors until they are mounted, failure to follow this precaution can lead to deformation or damage to these connectors.</li> <li>■ Provide another form of support to the PCB, this connector was not designed to be the main form of support.</li> <li>■ Mating and unmating with excessive force can cause damage.</li> <li>■ Do not apply excessive amounts of flux as it may cause excess solder and flux wicking.</li> <li>■ There may be a slight variance in the color of the molding between production lots, this variance will not affect the performance of the connector.</li> <li>■ Refer to the next page for the handling precautions when mating and unmating the connectors.</li> <li>■ If the connector becomes disconnected due to impact, a fall or a counterforce to the FPC, it may be necessary to hold the connector in place with an addition to the device's case or other cushioning material to hold the connector in place.</li> </ul>								

Dec. 1. 2021 Copyright 2021 HIROSE ELECTRIC CO., LTD. All Rights Reserved.

◆Precautions when connector mating

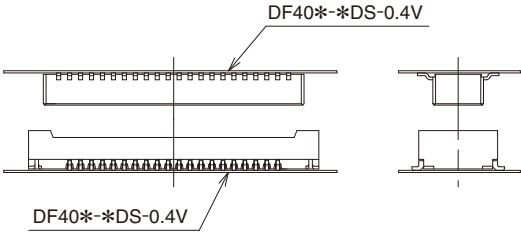
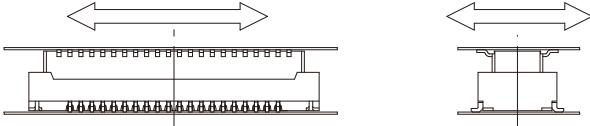
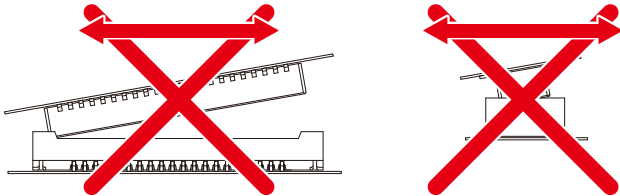
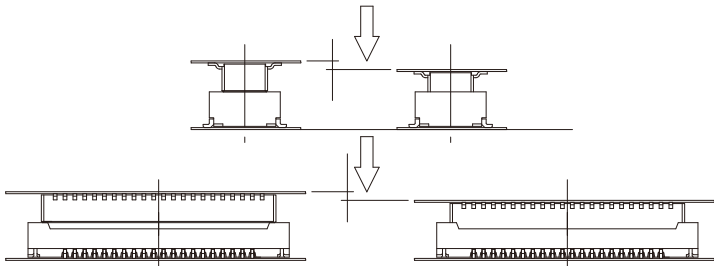
	
	
	<p>Prior to mating, locate the guidance ribs and align the header. Do not apply excess force to the connector during mating. Doing so can lead to contact damage.</p>
	<p>Make sure that the connector is parallel to the other side, it then will drop down slightly. Continue to press it down until it is fully mated while maintaining the angle. Do not apply excessive force as it may damage the contacts.</p>

Dec.1.2021 Copyright 2021 HIROSE ELECTRIC CO., LTD. All Rights Reserved.

### ◆ Precautions when unmating a connector

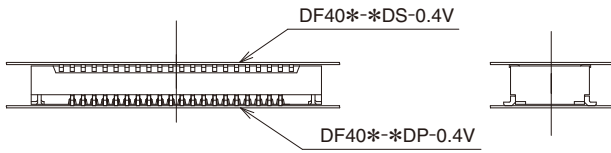
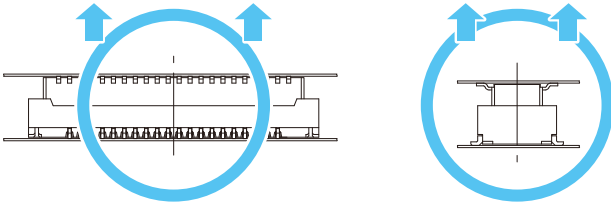
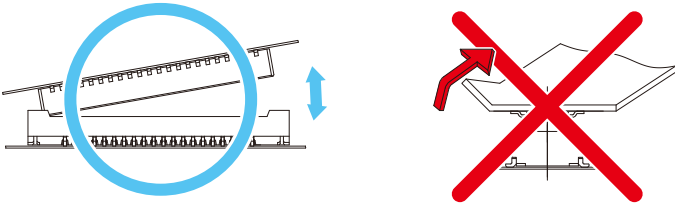
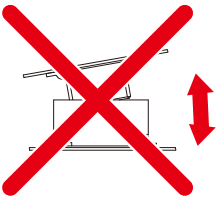
 <p>DF40*-DS-0.4V DF40*-DP-0.4V</p>	
	<p>To unmate this connector, lift evenly across the header, making sure that each side stays parallel to each other.</p>
 <p><b>Pitch direction</b>      <b>Corner direction</b></p>	<p>If circumstances prevent the connectors from staying parallel to each other, then one side may be lifted as shown in the diagram. This method is only approved if the connector is mounted onto an extremely rigid circuit board. If the board were to warp during this process it may result in damage to the connector or its solder joints.</p> <p>Do not try to disconnect these connectors by pulling on one side or a corner, or unmate it while it is securely mounted onto a rigid FPC. These actions may lead to deformities and ultimately a damaged connector.</p>
 <p><b>Width direction</b></p>	<p>As shown in the figure to the left, do not unmate it from the width direction (front to back), it may damage contacts.</p>

Dec.1.2021 Copyright 2021 HIROSE ELECTRIC CO., LTD. All Rights Reserved.

## ◆Precautions when unmating a connector

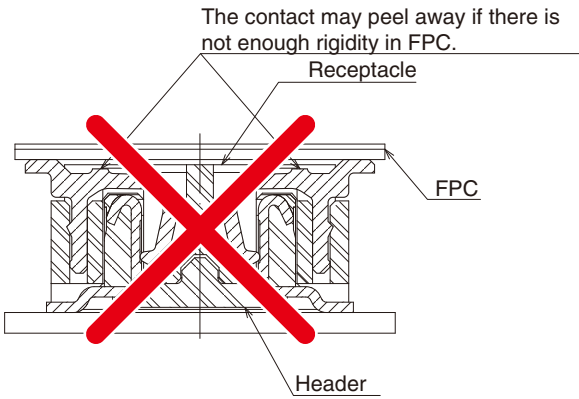
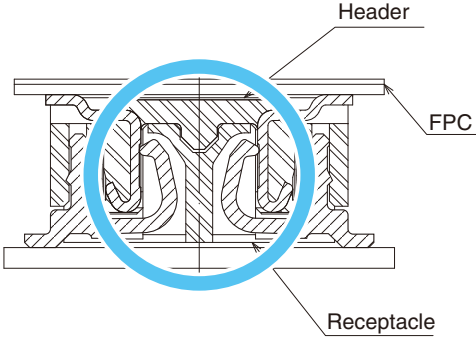
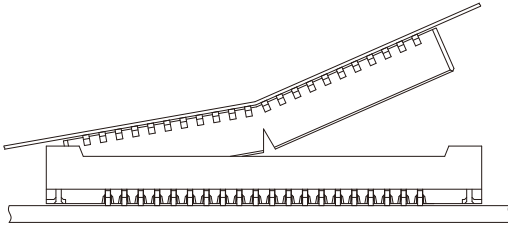
<p>The contact may peel away if there is not enough rigidity in FPC.</p> 	<p>When mounting the receptacle side to FPC which does not have enough rigidity, the contact may peel away soldered connection.</p> <p>We recommended to mount the header side to the FPC.</p>
	<p>We have conducted evaluations on the requirements needed for FPC rigidity. If you need to mount the receptacle to the FPC, contact your local Hirose Rep for this data.</p>
	<p>Even when mounting the header side to FPC, if the rigidity of FPC is low, the connector may break as shown in the left figure. Please check the strength and durability of FPC before using.</p> <p>For the evaluation results of each item and FPC rigidity, please contact us.</p>

Dec.1.2021 Copyright 2021 HIROSE ELECTRIC CO., LTD. All Rights Reserved.

**USA:**

**HIROSE ELECTRIC (U.S.A.), INC. HEADQUARTERS CHICAGO OFFICE**  
2300 Warrenville Road, Suite 150,  
Downers Grove, IL 60515  
Phone : +1-630-282-6700  
<http://www.hirose.com/us/>

**USA:**

**HIROSE ELECTRIC (U.S.A.), INC. BOSTON OFFICE**  
300 Brickstone Square Suite 201,  
Andover, MA 01810  
Phone : +1-978-662-5255

**GERMANY:**

**HIROSE ELECTRIC EUROPE B.V. NUREMBERG OFFICE**  
Neumeyerstrasse 22-26, 90411 Nurnberg  
Phone : +49-911 32 68 89 63  
Fax : +49-911 32 68 89 69  
<http://www.hirose.com/eu/>

**UNITED KINGDOM:**

**HIROSE ELECTRIC EUROPE BV (UK BRANCH)**  
4 Newton Court, Kelvin Drive, Knowlhill,  
Milton Keynes, MK5 8NH  
Phone : +44-1908 202050  
Fax : +44-1908 202058  
<http://www.hirose.com/eu/>

**CHINA:**

**HIROSE ELECTRIC (CHINA) CO., LTD. SHENZHEN BRANCH**  
Room 09-13, 19/F, Office Tower Shun Hing Square, Di Wang Commercial Centre,  
5002 Shen Nan Dong Road, Shenzhen City, Guangdong Province, 518008  
Phone : +86-755-8207-0851  
Fax : +86-755-8207-0873  
<http://www.hirose.com/cn/>

**KOREA:**

**HIROSE KOREA CO.,LTD.**  
143, Gongdan 1-daero, Siheung-si,  
Gyeonggi-do, 15084, Korea  
Phone : +82-31-496-7000  
Fax : +82-31-496-7100  
<http://www.hirose.co.kr/>

**INDIA:**

**HIROSE ELECTRIC SINGAPORE PTE. LTD. BANGALORE LIAISON OFFICE**  
Unit No-403, 4th Floor, No-84, Barton Centre, Mahatma  
Gandhi (MG) Road, Bangalore 560 001, Karnataka, India  
Phone : +91-80-4120 1907  
Fax : +91-80-4120 9908  
<http://www.hirose.com/sg/>

**USA:**

**HIROSE ELECTRIC (U.S.A.), INC. SAN JOSE OFFICE**  
2841 Junction Ave, Suite 200  
San Jose, CA. 95134  
Phone : +1-408-253-9640  
Fax : +1-408-253-9641  
<http://www.hirose.com/us/>

**THE NETHERLANDS:**

**HIROSE ELECTRIC EUROPE B.V.**  
Hogehillweg #8 1101 CC Amsterdam Z-0  
Phone : +31-20-6557460  
Fax : +31-20-6557469  
<http://www.hirose.com/eu/>

**GERMANY:**

**HIROSE ELECTRIC EUROPE B.V. HANOVER OFFICE**  
Bayernstr. 3, Haus C 30855 Langenhagen, Germany  
Phone : +49-511 97 82 61 30  
Fax : +49-511 97 82 61 35  
<http://www.hirose.com/eu/>

**CHINA:**

**HIROSE ELECTRIC (CHINA) CO., LTD. (SHANGHAI, HEADQUARTERS)**  
18, Enterprise Center Tower 2, 209# Gong He  
Road, Jing'an District, Shanghai, CHINA 200070  
Phone : +86-21-6391-3355  
Fax : +86-21-6391-3335  
<http://www.hirose.com/cn/>

**HONG KONG:**

**HIROSE ELECTRIC HONGKONG TRADING CO., LTD.**  
Room 1001, West Wing, Tsim Sha Tsui Centre, 66  
Mody Road, Tsim Sha Tsui East, Kowloon, Hong Kong  
Phone : +852-2803-5338  
Fax : +852-2591-6560  
<http://www.hirose.com/hk/>

**SINGAPORE:**

**HIROSE ELECTRIC SINGAPORE PTE. LTD.**  
03, Anson Road, #20-01, Springleaf Tower,  
Singapore 079909  
Phone : +65-6324-6113  
Fax : +65-6324-6123  
<http://www.hirose.com/sg/>

**MALAYSIA:**

**PENANG REPRESENTATIVE OFFICE**  
73-3-1, Ideal@The One, Jalan Mahsuri, Bayan  
Lepas Penang, 11950, Malaysia  
Phone : +604-648-5536  
<http://www.hirose.com/sg/>

**USA:**

**HIROSE ELECTRIC (U.S.A.), INC. DETROIT OFFICE (AUTOMOTIVE)**  
17197 N. Laurel Park Drive, Suite 253,  
Livonia, MI 48152  
Phone : +1-734-542-9963  
Fax : +1-734-542-9964  
<http://www.hirose.com/us/>

**GERMANY:**

**HIROSE ELECTRIC EUROPE B.V. GERMAN BRANCH**  
Schoenbergstr. 20, 73760 ostfildern  
Phone : +49-711-456002-1  
Fax : +49-711-456002-299  
<http://www.hirose.com/eu/>

**FRANCE:**

**HIROSE ELECTRIC EUROPE B.V. PARIS OFFICE**  
130 Avenue Joseph Kessel, Bat E, 78960  
Voisins le Bretonneux, France  
Phone : +33-1-85764886  
Fax : +33-1-85764823  
<http://www.hirose.com/eu/>

**CHINA:**

**HIROSE ELECTRIC (CHINA) CO.,LTD. BEIJING BRANCH**  
A1001, Ocean International Center, Building 56# East 4th  
Ring Middle Road, ChaoYang District, Beijing, 100025  
Phone : +86-10-5165-9332  
Fax : +86-10-5908-1381  
<http://www.hirose.com/cn/>

**TAIWAN:**

**HIROSE ELECTRIC TAIWAN CO., LTD.**  
103 8F, No.87, Zhengzhou Rd., Taipei  
Phone : +886-2-2555-7377  
Fax : +886-2-2555-7355  
<http://www.hirose.com/tw/>

**INDIA:**

**HIROSE ELECTRIC SINGAPORE PTE. LTD. DELHI LIAISON OFFICE**  
Office NO.552, Regus-Green Boulevard, Level5, Tower C,  
Sec62, Plot B-9A, Block B, Noida, 201301, Uttar Pradesh, India  
Phone : +91-12-660-8018  
Fax : +91-120-4804949  
<http://www.hirose.com/sg/>

**THAILAND:**

**BANGKOK OFFICE (REPRESENTATIVE OFFICE)**  
Unit 4703, 47th FL., 1 Empire Tower, South Sathorn  
Road, Yannawa, Sathorn, Bangkok 10120 Thailand  
Phone : +66-2-686-1255  
Fax : +66-2-686-3433  
<http://www.hirose.com/sg/>

**HIROSE ELECTRIC CO.,LTD.**

2-6-3,Nakagawa Chuoh,Tsuzuki-Ku,Yokohama-Shi 224-8540,JAPAN  
TEL: +81-45-620-3526 Fax: +81-45-591-3726  
<http://www.hirose.com>  
<http://www.hirose-connectors.com>