

# 承認書

## Specification For Approval

Customer: (客戶)

\_\_\_\_\_

Description: (產品描述) SMDLED2835 0.5W 蓝光

\_\_\_\_\_

Part number: (產品型號) TJ-S2835B05HQ88DL-A3

\_\_\_\_\_

Date: (日期)

\_\_\_\_\_

Approved By: (客戶承認)

--

Prepared By: (我司承認)

Approval	Check	Design	Sales
----------	-------	--------	-------

核准

審核

製作

業務

Customer Service Hotline: **400-676-8616**

TEL: 0769-8662 5999      0769-8200 2226

E-MAIL : dg@togialed.com

FAX: 0769-8200 2227

WEB: www.togialed.com

**Package Dimensions (封装尺寸)**

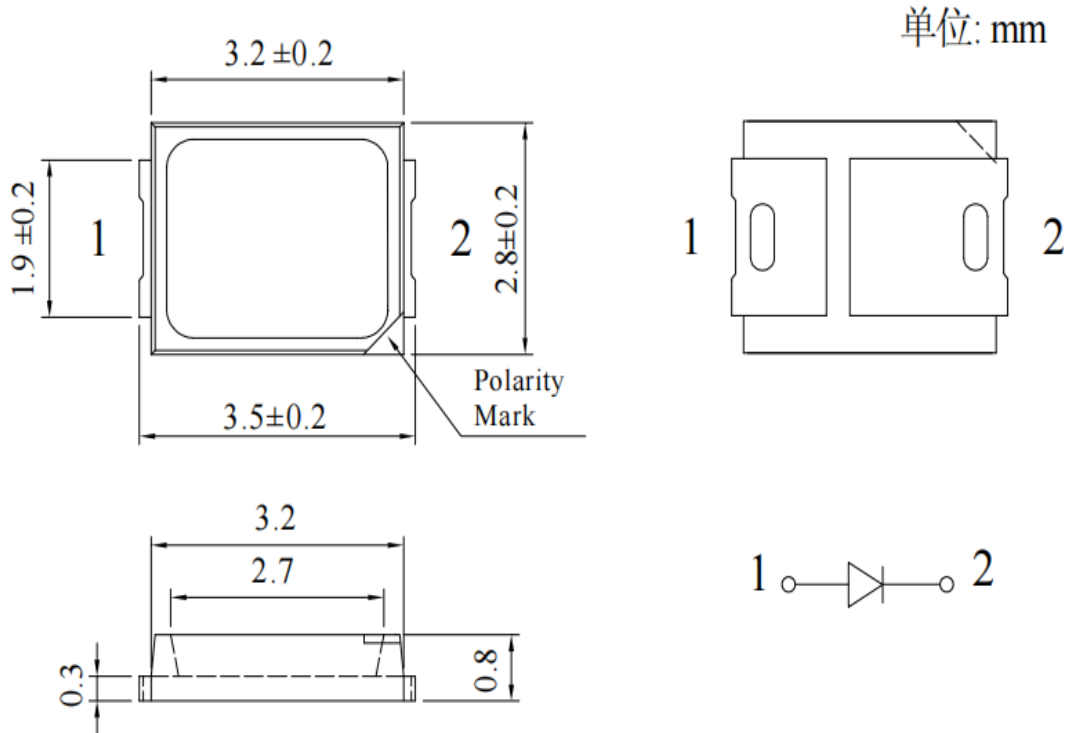

**Recommended Soldering Patter (n 推荐焊盘式样)**

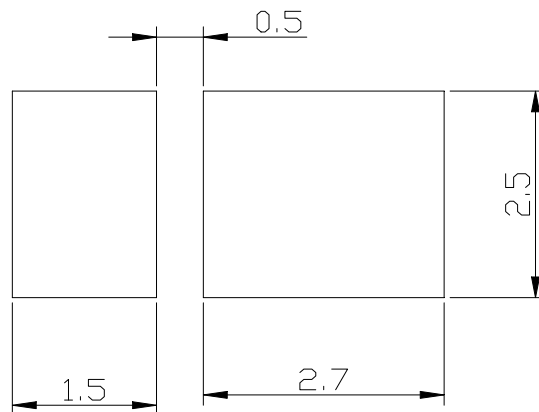

**Note :**

- 1: All dimensions are in millimeters (inches).
- 2: Tolerance is  $\pm 0.25$ mm (.010") unless otherwise noted.
- 3: Specifications are subject to change without notices.
- 4: This specification is for reference only for one year

**极限参数 Absolute maximum ratings**
**(Ta=25°C)**

参数 Parameter	符号 Symbol	数值 Value	单位 Unit
正向电流 Forward current	If	150	mA
反向耐压 Reverse voltage	Vr	5	V
耗散功率 Power dissipation	Pd	540	mW
工作环境温度 Operating temperature range	Top	-40~+80	°C
贮藏温度 Storage temperature range	Tstg	-40~+80	°C
峰值脉冲电流 Peak pulsing current (1/8 duty f=1KHz)	Ifp	300	mA
结温 Junction Temperature	Tj	105	°C/W
静电 Electrostatic Discharge(HBM)	ESD	2000	V

**光电特性 Electro-Optical characteristics**
**(TA=25°C)**

参数 Parameter	测试条件 Test Condition	符号 Symbol	颜色	数值 Value			单位 Unit
				Min	Typ	Max	
色温 Color Temperature	If=60mA	CCT	--	--	--	--	K
正向电压 Forward voltage	If=60mA	Vf	B	2.8	--	3.6	V
光通量 luminous flux	If=60mA	φ	B	6	--	15	LM
视角 Viewing angle at 50% IV	If=60mA	2θ1/2	B	--	120	--	Deg
主波长 Dominant wavelength	If=60mA	λd	B	460	--	470	nm
反向电流 Reverse current	Vr=5V	Ir	B	--	5	--	μA
显色性指数 Color Rendering Index	If=60mA	CRI	--	--	--	--	Ra

典型的光电特性曲线图表 Typical photo-electricity characteristic curve chart

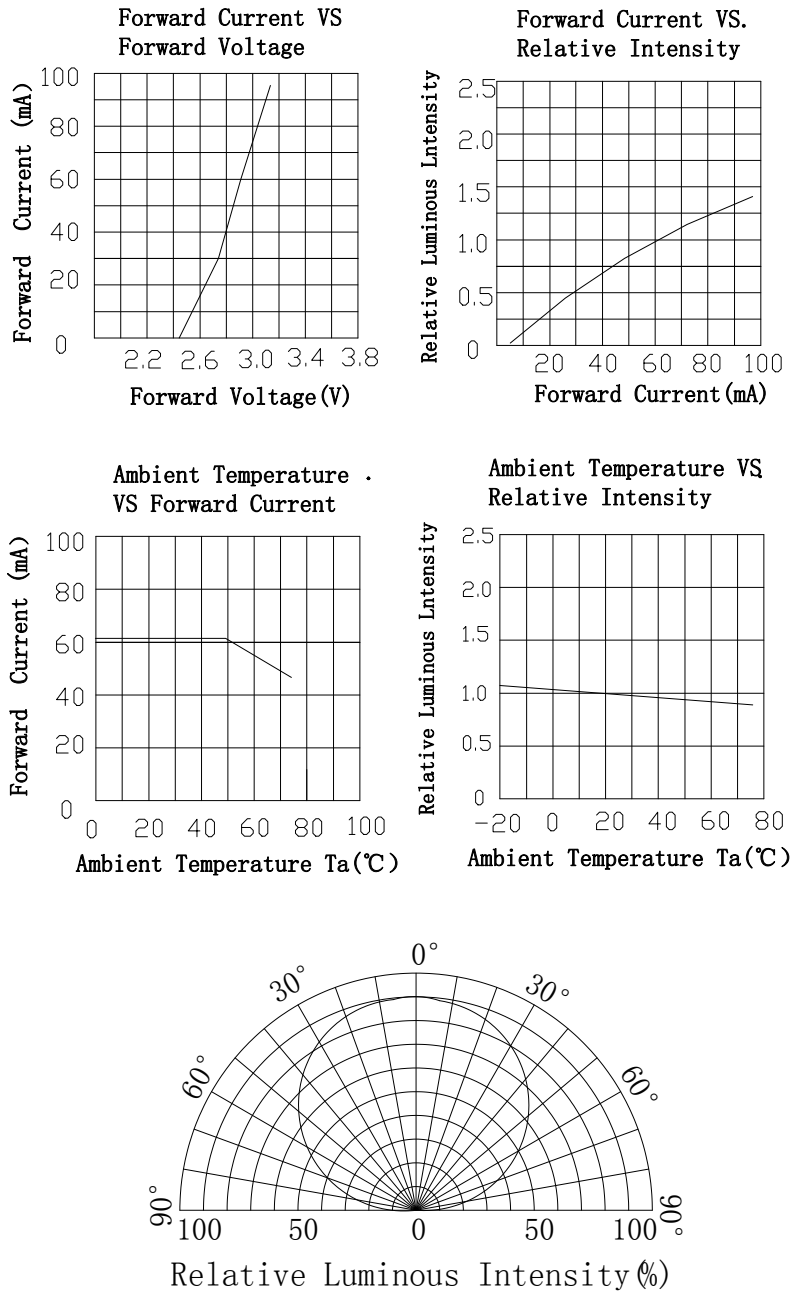

## 可靠性实验项目 Test items and results of reliability

类别 Type	测试项目 Test item	参照标准 Standard	测试条件 Test Conditions	备注 Note	数量 Quantity	不良数量 Number of Damaged
Environmental Sequence	高低温循环 Temperature Cycle	JIS C 7021 (1977)A-4	-25°C 30min ↑↓5min 80°C 30min	100 cycle	22	0
	热冲击 Thermal Shock	MIL-SLD-107D	-25°C 15min ↑↓5min 80°C 15min	50 cycle	22	0
	高湿度热循环 High Humidity Heat Cycle	JIS C 7021 (1977)A-5	30°C (<=>) 65°C 90%RH 24hrs/1cycle	10 cycle	22	0
	高温存储 High Temperature Storage	JIS C 7021 (1977)B-10	T <sub>a</sub> =80°C	1000hrs	22	0
	高温高湿存储 Humidity Heat Storage	JIS C 7021 (1977)B-11	T <sub>a</sub> =60°C RH=90%	1000hrs	22	0
	低温存储 Low Temperature Storage	JIS C 7021 (1977)B-12	T <sub>a</sub> =-30°C	1000hrs	22	0
Operation Sequence	常温寿命测试 Life Test	JIS C 7035 (1985)	T <sub>a</sub> =25°C I <sub>F</sub> = 60mA	1000hrs	22	0
	高温高湿寿命测试 High Humidity Heat Life Test	①	60°C RH=90% I <sub>F</sub> = 60mA	500hrs	22	0
	低温寿命测试 Low Temperature Life Test	①	T <sub>a</sub> =-25°C I <sub>F</sub> = 60mA	1000hrs	22	0

①请参考可靠性测试标准规范。 Refer to reliability test standard specification for in this line.

## 失效判定标准 Criteria For Judging Damage

测试项目	符号	测试条件	判定标准
正向电压 Forward Voltage	V <sub>F</sub>	I <sub>F</sub> =I <sub>FT</sub>	初始值±10% Initial Data±10%
反向电流 Reverse Current	I <sub>R</sub>	V <sub>R</sub> =5V	I <sub>R</sub> ≤ 10μA
光强 Luminous Intensity	I <sub>V</sub>	I <sub>F</sub> =I <sub>FT</sub>	平均 I <sub>V</sub> 衰减 ≤ 30%，单个平均 I <sub>V</sub> 衰减 ≤ 50% Average I <sub>V</sub> degradation ≤ 30% Single LED I <sub>V</sub> degradation ≤ 50%
耐焊接热 Resistance to Soldering Heat	--	--	材料无内部裂痕、无材料间爆裂、剥离、无死灯 Material without internal cracks, no material between stripped, no deaded light.

\*数据工作表中所示的技术信息仅限于典型特征和电路实例引用的产品。它既不构成工业特性的保证，也不构成任何许可的授权

The technical information shown in the data sheets are limited to the typical characteristics and circuit examples of the referenced products. It does not constitute the warranting of industrial property nor the granting of any license.

## 焊接指导 Guideline for Soldering

1、回流焊接：推荐以下无铅回流焊接温度图进行。

**Reflow Soldering:** Use the conditions shown in the under Figure of Pb-Free Reflow Soldering.

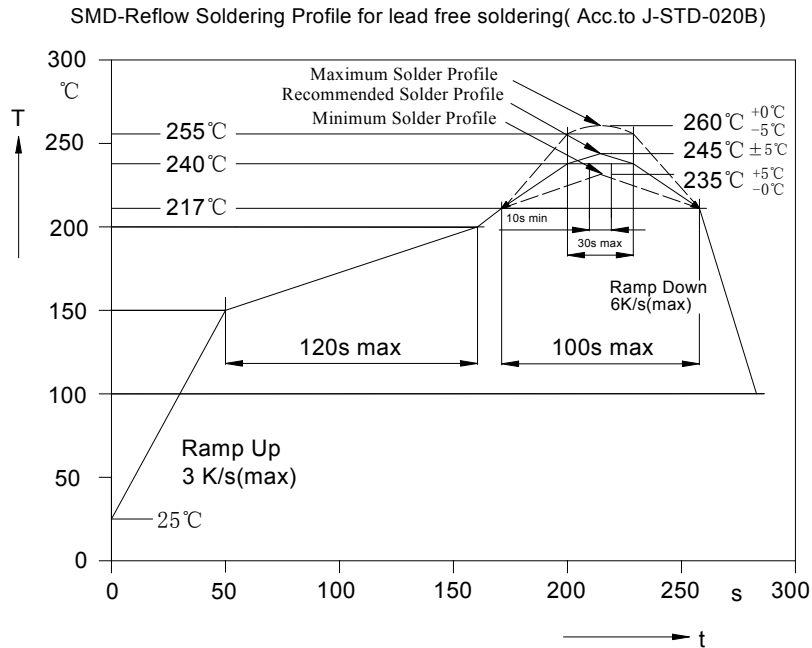

**Remark:** If not lead free soldering, the recommended solder profile is 230°C and max solder profile is 245°C.

## 2、使用烙铁人手焊接 Hand Soldering

1)、推荐使用低功率于 20W 的烙铁，焊接时烙铁的温度必须保持在 360°C 以下，且每个电极只能进行一次焊接，每次焊接的持续时间不得超过 3 秒。

A soldering iron of less than 20W is recommended to be used in Hand Soldering Please keep the temperature of the soldering iron under 360°C while soldering Each terminal of the LED is to go for less than 3 second and for onetime only.

2)、人手焊接过程中的不慎操作易引起 LED 产品的损坏，应当小心谨慎。

Be careful because the damage of the product is often started at the time of the hand soldering.

## 3、清洗 Cleaning

1)、在焊接后推荐使用酒精进行清洗，在温度不高于 30°C 的条件下持续 3 分钟，不高于 50°C 的条件下持续 30 秒，使用其他类似溶剂清洗前，请先确认使用的溶剂不会对 LED 的封装和环氧树脂造成损伤。

It is recommended that alcohol be used as a solvent for cleaning after soldering. Cleaning is to go under 30°C for 3 minutes or 50°C for 30 seconds. When using other solvents, it should be confirmed beforehand whether the solvents will dissolve the package and the resin or not.

2)、超声波清洗也是有效的方法，一般最大功率不应超过 300W，否则可能对 LED 造成损伤，请根据具体的情况预先测试清洗条件是否会对 LED 造成损伤。

Ultrasonic cleaning is also an effective way for cleaning. But the influence of Ultrasonic cleaning on LED depends on factors such an ultrasonic power. Generally, the ultrasonic power should not be higher than 300W. Before cleaning, a pre-test should be done to confirm whether any damage to LEDs will occur.

## 编带和包装 Tape and Packaging

### 1、带盘 Tape leader and reel

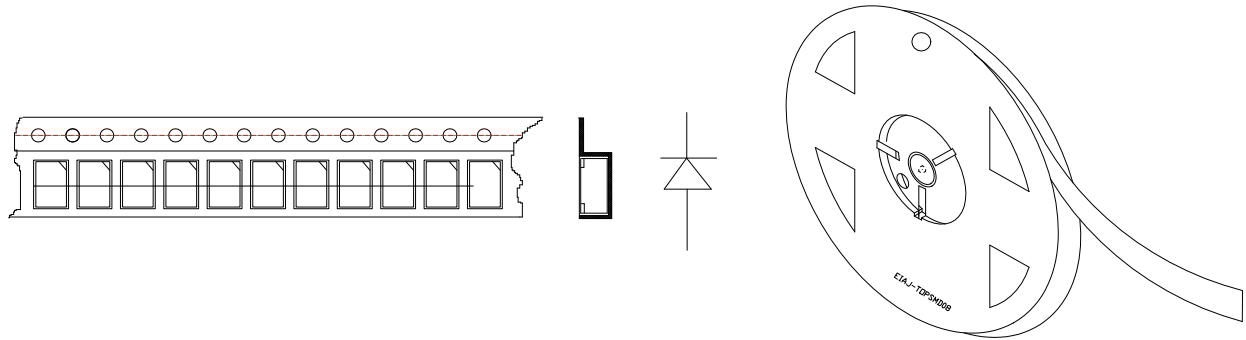

### 2、防潮袋包装 Moisture Resistant Packaging

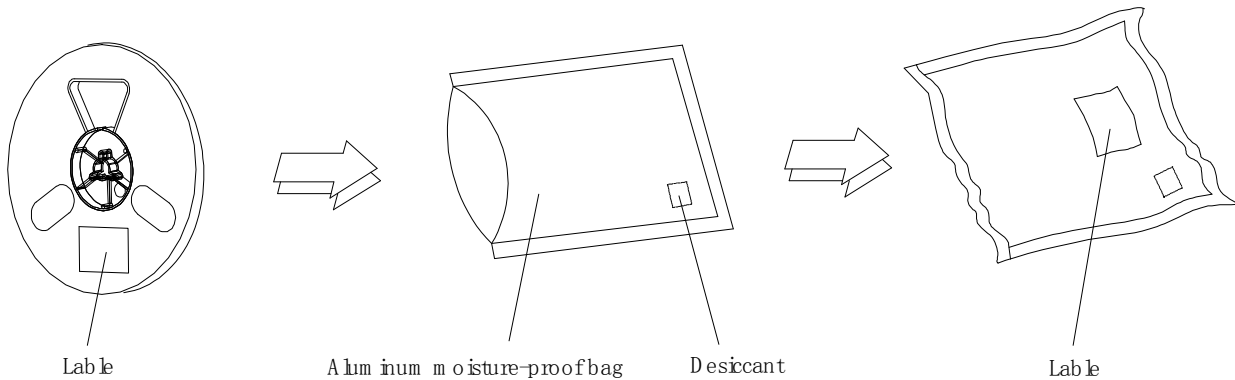

### 3、注意事项 Cautions

1)、LED 封装为硅胶，故 LED 胶体表面较软，用力按压胶体表面会影响 LED 可靠性，因此应有预防措施避免在封装的零件上的强大压力，当使用吸嘴时，胶体表面的压力应是恰当的。

The encapsulated material of the LEDs is silicone. Therefore the LEDs have a soft surface on the top of package. The pressure to the top surface will be influence to the reliability of the LEDs. Precautions should be taken to avoid the strong pressure on the encapsulated part. So when use the picking up nozzle, the pressure on the silicone resin should be proper.

2)、SMD 吸嘴的外径不应超过 LED 的尺寸以避免漏气。吸嘴的内径应尽可能大。吸嘴头建议使用柔软的材料以避免 LED 硅胶表面划伤或损坏。

The outer diameter of the SMD pickup nozzle should not exceed the size of the LED to prevent air leaks. The inner diameter of the nozzle should be as large as possible. pliable material is suggested for the nozzle tip to avoid scratching or damaging the LED surface during pickup.

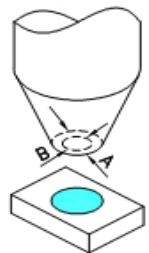

## 处理防备措施 Handling Precautions

- 1、 通过使用适当的工具从材料侧面夹取，不可直接用手或尖锐金属压胶体表面，它可能会损坏内部电路。  
Handle the component along the side surface by using forceps or appropriate tools; do not directly touch or  
Handle the  
silicone lens surface, it may damage the internal circuitry.

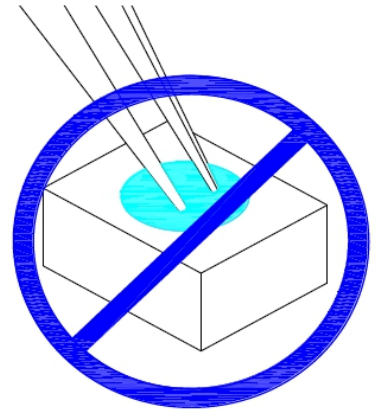
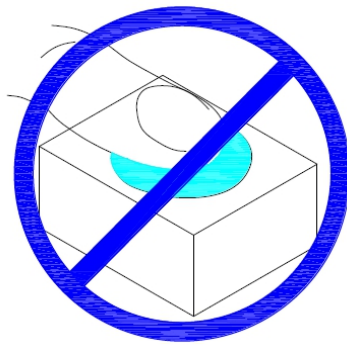
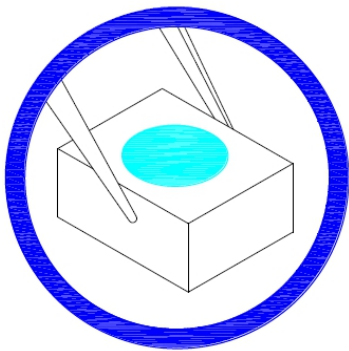

- 2、 不可将模组材料堆积在一起，它可能会损坏内部电路  
Do not stack together assembled PCBs containing LEDs.  
PH<7  
Impact may scratch the silicone lens or damage the internal  
circuitry

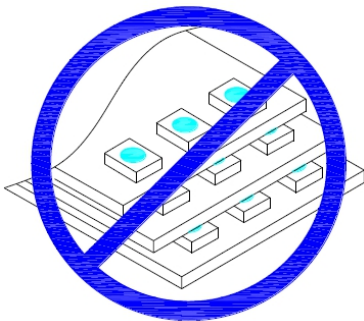

- 3、 不可用在 PH<7 的酸性场所  
Not suitable to operate in acidic envi-ronment,



## Operation precautions 操作注意事项

1. It is suggested that reflow soldering should not be more than twice, and the temperature curve should meet the standard, and the maximum temperature should not exceed 260 °C;  
回流焊建议不要超过两次,且温度曲线符合标准,最高不超过 260°C,避免胶体过度膨胀死灯;
2. In the process of operation, do not press the colloidal surface of the lamp bead in front. It is recommended to use special tweezers to operate from the side;  
在作业过程中,请勿正面按压灯珠胶体表面,建议使用专用镊子从侧面操作;
3. After reflow soldering, do not stack one side of PCB board containing exposed LED together. External impact may scratch the colloid and cause damage to internal circuit;  
回流焊后,不要将含有暴露 LED 的一面 PCB 板堆叠在一起,外部的冲击可能会划伤胶体导致内部电路损坏;
4. After welding to PCB, it is not recommended to bend the PCB board, which may cause dark crack of the bracket and not bright during assembly;  
焊接到 PCB 板后,不建议弯曲 PCB 板,这样可能会造成支架出现暗裂,在组装时出现不亮;
5. In SMT, a proper suction nozzle should be larger than the luminous surface of the lamp bead colloid to prevent damage to the colloid of the lamp bead or the internal circuit until the lamp is not on;  
SMT 时采用合适的吸嘴,应大于灯珠胶体发光面,防止损伤灯珠胶体或内部电路至死灯不亮;
6. Pay attention to static electricity when operating LED. If the static electricity is too high, it will break down the internal chip, resulting in poor short circuit. Wear anti-static Bracelet during operation, and the production machinery must be grounded;  
操作 LED 时,注意静电,静电过大会击穿内部芯片,造成短路不良,作业时应佩戴防静电手环,生产机械必须接地;

## Precautions for use 使用注意事项

1. Please pay attention not to use in the environment with serious acid and alkali and sulfur ion serious chemical sites, which may lead to excessive corrosion of LED colloid and bracket, and eventually led does not light up;  
请注意使用环境勿在带酸性严重以及硫离子严重的化工场所,这样可能会使 LED 胶体以及支架过度腐蚀,最终导致 LED 不亮;
2. If it is used in humid environment or outdoor for a long time, waterproof work should be done to avoid short circuit or dead light phenomenon of lamp bead due to damp;  
如长期在潮湿环境下或室外使用,应做好防水工作,避免灯珠因受潮出现短路或死灯现象;
3. In the use of LED lamp beads, heat dissipation should be done well. Long term work under high temperature will accelerate the aging of LED lamp beads, light failure, and even death of light;  
LED 灯珠在使用工作过程中,应做好散热工作,长期在高温状态下工作,会使 LED 灯珠加速老化,光衰,严重的会出现死灯不良;
4. Please strictly refer to the electrical parameters recommended by our company to avoid other adverse phenomena;  
请严格参照我司建议的电性参数使用,避免出现其他不良现象;