



**B-LINK®**

## **BL-R8723BT1**

**802.11n 150Mbps USB**

**WiFi and BT Combo Module Specification**

**SHENZHEN BILIAN ELECTRONIC CO., LTD**

Add: 10~11/F, Building 1A, Huaqiang idea park, Guangming district, Shenzhen. Guangdong, China

Web: [www.b-link.net.cn](http://www.b-link.net.cn)

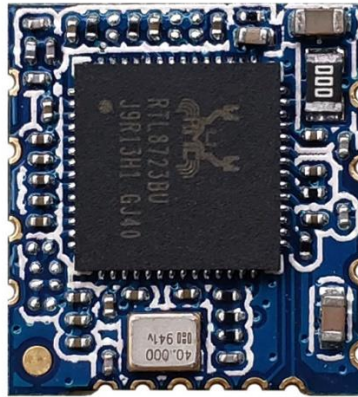

Module Name: BL-R8723BT1

Module Type: 802.11b/g/n 150Mbps 1T1R USB WiFi and BT combo Module

Revision: V1.1

Customer Approval:

Company:

Title:

Signature:

Date:

BL-link Approval:

Title:

Signature:

Date:

## Revision History

Revision	Summary	Release Date
1.0	Official release	2020-06-28
1.1	Optimal description	2021-09-28

## 1. Introduction

BL-R8723BT1 is a highly integrated single-chip 802.11n Wireless LAN (WLAN) USB 2.0 Multi-Function network interface controller with integrated Bluetooth 2.1/3.0/4.0 controller. It combines a WLAN MAC, a 1T1R capable WLAN baseband, and RF in a single chip. The RTL8723BU provides a complete solution for a high-performance integrated wireless and Bluetooth device. The integration provides better coordination between 802.11 and Bluetooth, and with sophisticated dynamic power control and packet traffic arbitration, RTL8723BU is able to provide the best coexistence performance Overview.

### 1.1 Features

- Operating Frequencies: 2.4~2.4835GHz
- Host Interface is USB 2.0
- IEEE Standards: IEEE 802.11b/g/n
- BT2.1+EDR/BT3.0 and BT LE4.0
- Wireless data rate can reach up to 150Mbps
- Connect to external antenna through half hole pad
- Power Supply: 3.3±0.2V main power and VDIO power supply

### 1.2 Block Diagram

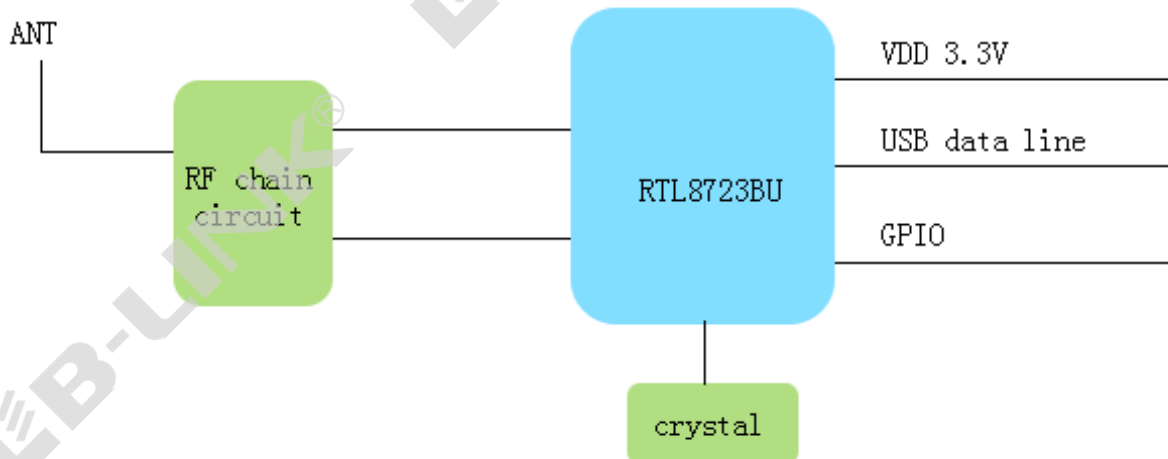

## 1.3 General Specifications

Module Name	BL-R8723BT1 WiFi and BT combo Module
Chipset	RTL8723BU-CG
WiFi Standards	IEEE802.11b/g/n, 1T1R, 2.4GHz, 150Mbps (Max)
BT Standards	V2.1+EDR/BT v3.0/BT v3.0+HS/BT v4.0
Host Interface	USB 2.0
Antenna	Connect to the external antennas through half hole pad
Dimension	SMD 14Pins, 12.2*13.4*1.6mm (L*W*H)
Power Supply	DC 3.3±0.2V (TX mode) @ 300 mA (Max)
Operation Temperature	-10°C to +70°C
Operation Humidity	10% to 95% RH (Non-Condensing)

## 2. Pin Assignments

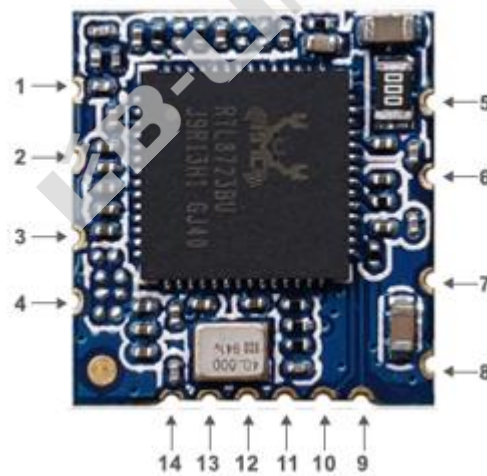

Top view

### 2.1 Pin Definition

No	Pin Name	Type	Description	Supply
1	GND	P	Ground connections	
2	RF0	RF	WLAN and BT RF port	
3	NC	NC	NC	

4	SUS CLK	P	External 32K or RTC clock input. This pin	
5	GND	P	Ground connections	
6	USB_DP	I/O	USB Transmitter/Receiver Differential Pair	
7	USB_DM	I/O	USB Transmitter/Receiver Differential Pair	
8	VDD33	P	VDD 3.3V Power Supply	
9	CHIP WAKE HOST	O	Chip Wakeup host pin	
10	HOST WAKE CHIP	I	Host Wakeup Chip pin	
11	PCM CLK	I/O	PCM Clock This pin	
12	PCM SYNC	I/O	PCM frame Synchronization	
13	PCM OUT	O	PCM data Output. This pin	
14	PCM IN	I	PCM data Input. This pin	

P: Power, I: Input, O: Output, I/O: In/Output, RF: Analog RF Port

### 3. Electrical and Thermal Specifications

#### 3.1 Recommended Operating Conditions

Parameters	Min	Typ	Max	Units	
Ambient Operating Temperature	-10	25	70	°C	
External Antenna VSWR	1	1.92	2.5	/	
Supply Voltage	VDD33	3.1	3.3	3.5	V

#### 3.2 Current Consumption

Conditions : VDD33=3.3V ; Ta:25°C			
Use Case	VDD33 Current (average)		
	Typ	Max	Units
WiFi Radio Off (Linux Driver)	42	50	mA
WiFi Unassociated (Linux Driver)	40	60	mA
2.4G 1Mbps TX (RF-Test)	225	255	mA
2.4G 1Mbps RX (RF-Test)	134	135	mA
2.4G 11Mbps TX (RF-Test)	230	246	mA

2.4G 11Mbps RX (RF-Test)	130	132	mA
2.4G 6Mbps TX (RF-Test)	220	285	mA
2.4G 6Mbps RX (RF-Test)	133	134	mA
2.4G 54Mbps TX (RF-Test)	210	290	mA
2.4G 54Mbps RX (RF-Test)	133	135	mA
2.4G MCS0(HT20) TX (RF-Test)	255	272	mA
2.4G MCS0(HT20) RX (RF-Test)	132	135	mA
2.4G MCS7(HT20) TX (RF-Test)	185	285	mA
2.4G MCS7(HT20) RX (RF-Test)	133	134	mA
2.4G MCS7(HT40) TX (RF-Test)	201	278	mA
2.4G MCS7(HT40) RX (RF-Test)	133	135	mA
BT BR_1M DH5 TX(RF-Test)	125	152	mA
BT EDR_3M DH5 TX(RF-Test)	119	147	mA
BT LE_1M TX(RF-Test)	122	161	mA
BT BR_1M DH5 RX Active(RF-Test)	103	127	mA
BT EDR_3M DH5 RX Active(RF-Test)	102	130	mA
BT LE_1M RX Active(RF-Test)	110	133	mA

## 4. Interface Functional and Timing Specifications

### 4.1 USB Power On Sequence

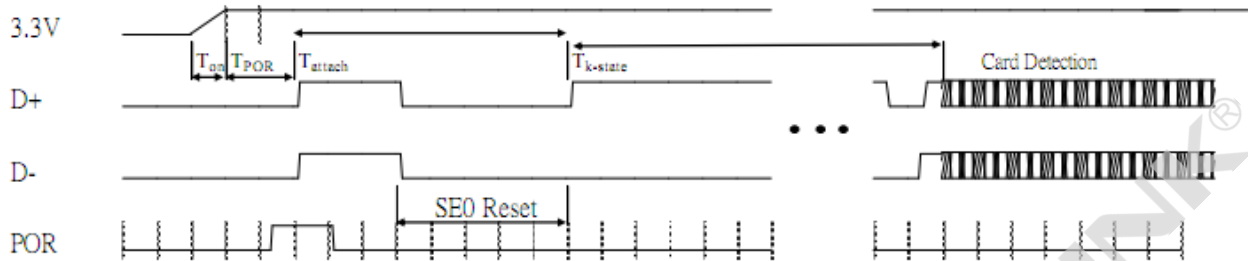

## 5. WiFi RF Specifications

### 5.1 2.4G WiFi RF Specification

Conditions : VDD33=3.3V ; Ta:25°C			
Features	Description		
WLAN Standard	IEEE 802.11b/g/n CSMA/CA		
Frequency Range	2.4~2.4835GHz (2.4GHz ISM Band)		
Channels	Ch1~Ch13 (For 20MHz Channels)		
Modulation	802.11b (DSSS): DBPSK, DQPSK, CCK; 802.11g (OFDM): BPSK, QPSK, 16QAM, 64QAM; 802.11n (OFDM): BPSK, QPSK, 16QAM, 64QAM;		
Date Rate	802.11b: 1, 2, 5.5, 11Mbps; 802.11g: 6, 9, 12, 18, 24, 36, 48, 54Mbps; 802.11n (HT20): MCS0~MCS7(1T1R_SISO) 6.5~72.2Mbps; 802.11n (HT40): MCS0~MCS7(1T1R_SISO) 13.5~150Mbps;		
Frequency Tolerance	$\leq \pm 25\text{ppm}$		
2.4G Transmitter Specifications			
TX Rate	TX Power	TX Power Tolerance	EVM
802.11b@1~11Mbps	17dBm	$\pm 1.5\text{dBm}$	$\leq -10\text{dB}$
802.11g@6Mbps	17dBm	$\pm 1.5\text{dBm}$	$\leq -10\text{dB}$
802.11g@54Mbps	15dBm	$\pm 1.5\text{dBm}$	$\leq -28\text{dB}$
802.11n@HT20_MCS0	16dBm	$\pm 1.5\text{dBm}$	$\leq -10\text{dB}$
802.11n@HT20_MCS7	14dBm	$\pm 1.5\text{dBm}$	$\leq -28\text{dB}$
802.11n@HT40_MCS0	16dBm	$\pm 1.5\text{dBm}$	$\leq -10\text{dB}$
802.11n@HT40_MCS7	14dBm	$\pm 1.5\text{dBm}$	$\leq -28\text{dB}$

2.4G Receiver Specifications			
RX Rate	Min Input Level(Typ)	Max Input Level(Typ)	PER
802.11b@1Mbps	-93dBm	-10dBm	< 8%
802.11b@11Mbps	-86dBm	-10dBm	< 8%
802.11g@6Mbps	-90dBm	-15dBm	< 10%
802.11g@54Mbps	-70dBm	-15dBm	< 10%
802.11n@HT20_MCS0	-88dBm	-15dBm	< 10%
802.11n@HT20_MCS7	-65dBm	-15dBm	< 10%
802.11n@HT40_MCS0	-86dBm	-15dBm	< 10%
802.11n@HT40_MCS7	-65dBm	-15dBm	< 10%

## 5.2 Bluetooth RF Specifications

Conditions : VDD33=3.3V ; Ta:25°C			
Features	Description		
Bluetooth Specification	Bluetooth v2.1+EDR/3.0+HS (Bluetooth Classic _ BT BR/EDR), Bluetooth 4.0 (Bluetooth Low Energy _ BT_LE) FHSS		
Frequency Range	2.4~2.4835GHz (2.4GHz ISM Band)		
Channels	Bluetooth Classic: Ch0~Ch78 (For 1MHz Channels); Bluetooth Low Energy: Ch0~Ch39 (For 2MHz Channels);		
Power Classes	Bluetooth Classic: Class1; Bluetooth Low Energy: Class1.5;		
Date Rate & Modulation	BR_1Mbps: GFSK; EDR_2Mbps: $\pi/4$ -DQPSK; EDR_3Mbps: 8DPSK; LE_1Mbps: GFSK;		
Bluetooth Transmitter Specifications			
Items	Min	Typ	Max
TX Power			
BR_1M TX Power	1	6	8
EDR_2/3M TX Power	1	6	8
LE_125K~1M TX Power	1	6	8
1DH1 TX Power	1	6	8

2DH3 TX Power	1	6	8	
3DH5 TX Power	1	6	8	
<b>BR_1M Modulation Characteristics</b>				
$\Delta f_{1avg}$	145kHz	163kHz	--	
$\Delta f_{2max}$ [For at least 99.9% of all $\Delta f_{2max}$ ]	143kHz	146kHz	⊖	
$\Delta f_{1avg} / \Delta f_{2max}$	1.01	0.12	--	
<b>EDR Modulation Accuracy</b>				
RMS DEVM (EDR_2M)	--	10%	20%	
99% DEVM (EDR_2M)	--	13%	30%	
Peak DEVM (EDR_2M)	--	17%	35%	
RMS DEVM (EDR_3M)	--	9%	13%	
99% DEVM (EDR_3M)	--	11%	20%	
Peak DEVM (EDR_3M)	--	14%	25%	
<b>LE_Modulation characteristics</b>				
$\Delta f_{1avg}$ (LE_1M)	207kHz	210kHz	--	
$\Delta f_{2max}$ [For at least 99.9% of all $\Delta f_{2max}$ ] (LE_1M)	195kHz	194kHz	--	
$\Delta f_{1avg} / \Delta f_{2max}$ (LE_1M)	1.06	1.08	--	
<b>Bluetooth Receiver Specifications</b>				
Items	Sensitivity		Maximum Input Level	
	Input Level(Typ)	BER	Input Level(Typ)	BER
BR_1M	-92dBm	$\leq 0.1\%$	-20dBm	$\leq 0.1\%$
EDR_2M	-90dBm	$\leq 0.01\%$	-20dBm	$\leq 0.1\%$
EDR_3M	-86dBm	$\leq 0.01\%$	-20dBm	$\leq 0.1\%$
LE_1M	-92dBm	$\leq 30.8\%$	-20dBm	$\leq 0.1\%$
1DH1	-92dBm	$\leq 30.8\%$	-20dBm	$\leq 0.1\%$
2DH3	-90dBm	$\leq 30.8\%$	-20dBm	$\leq 0.1\%$
3DH5	-86dBm	$\leq 30.8\%$	-20dBm	$\leq 0.1\%$

## 6. Mechanical Specifications

### 6.1 Module Outline Drawing

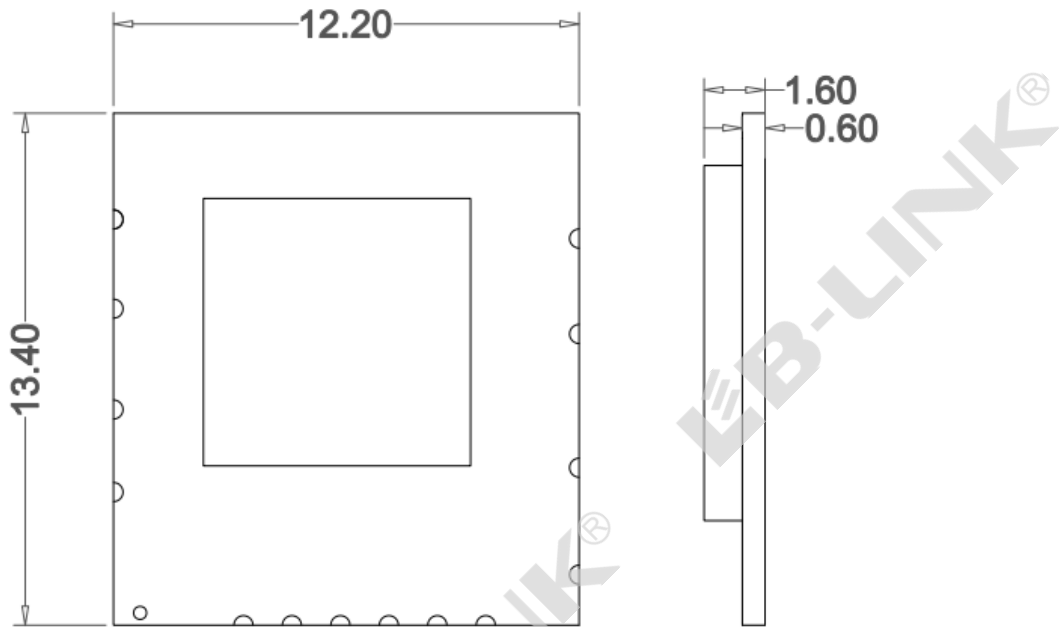

Module dimension: 13.4\*12.2\*1.6mm (L\*W\*H; Tolerance:  $\pm 0.15$ mm)

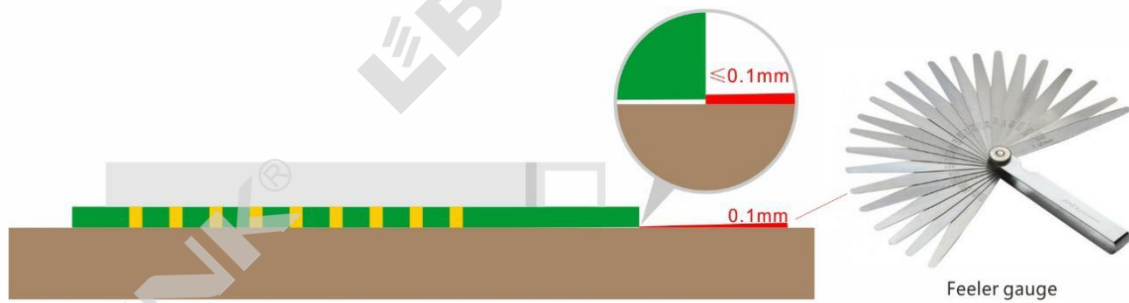

Module Bow and Twist:  $\leq 0.1$ mm

## 6.2 Mechanical Dimensions

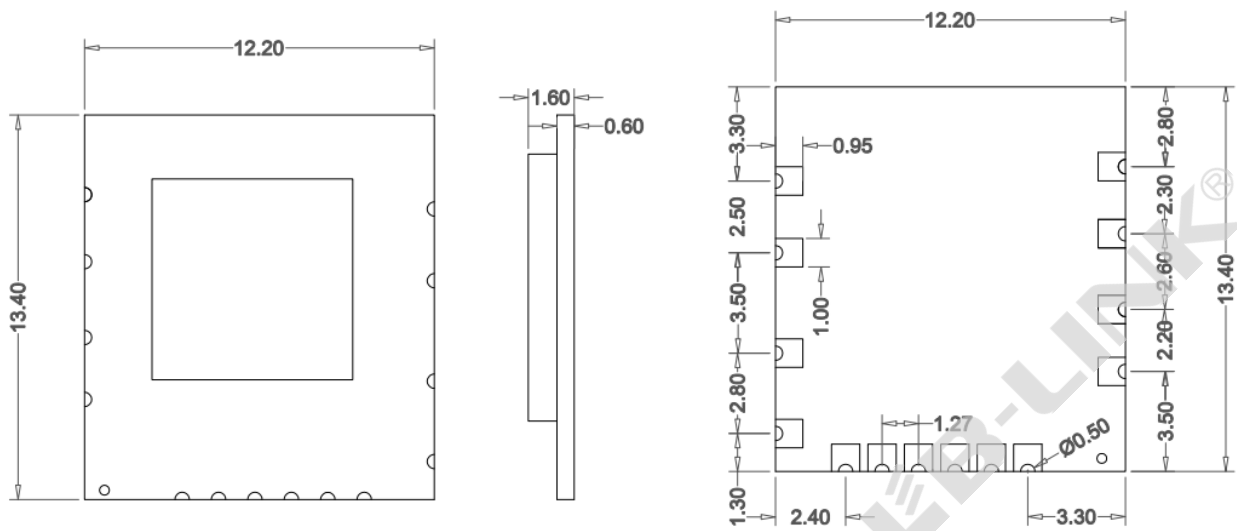

## 7. Application Information

### 7.1 Typical Application Circuit

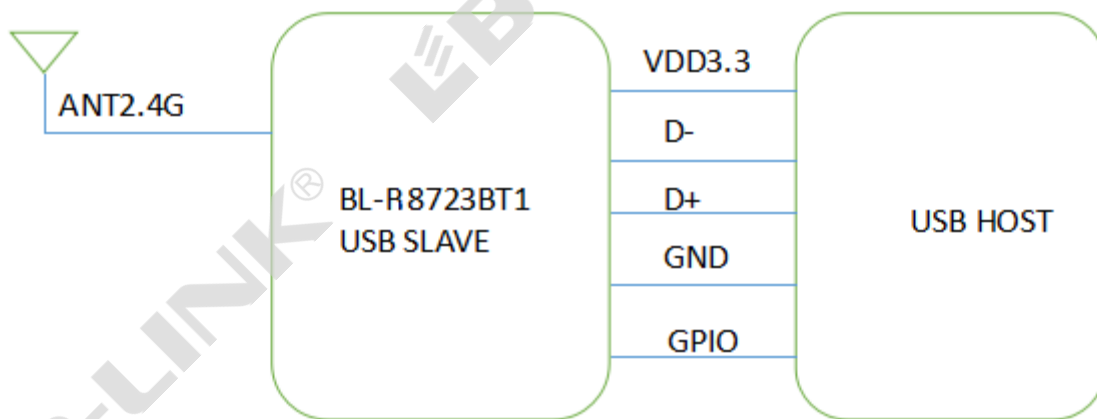

7.2 Recommend PCB Layout Footprint

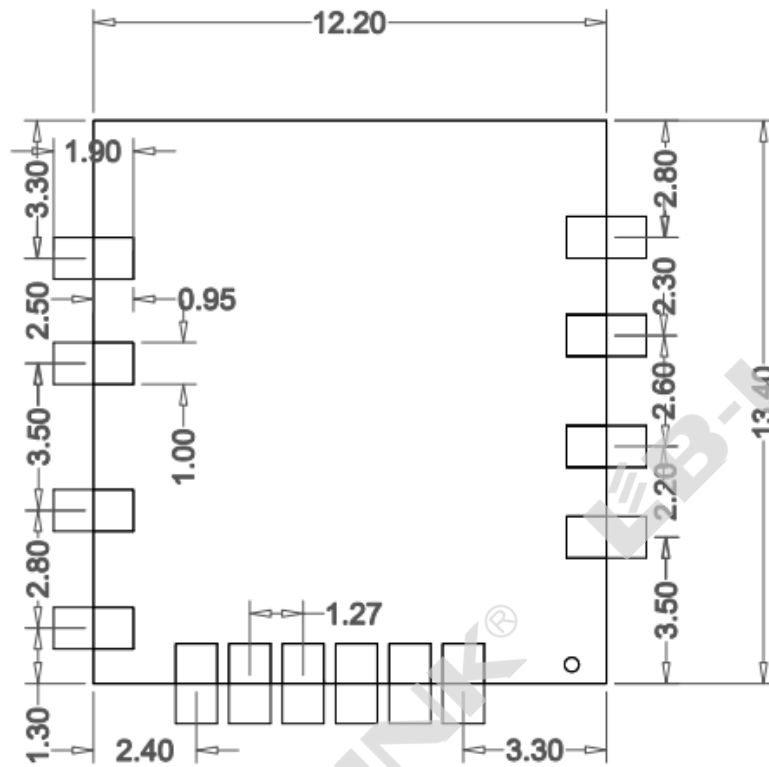

7.3 Reflow Soldering Standard Conditions

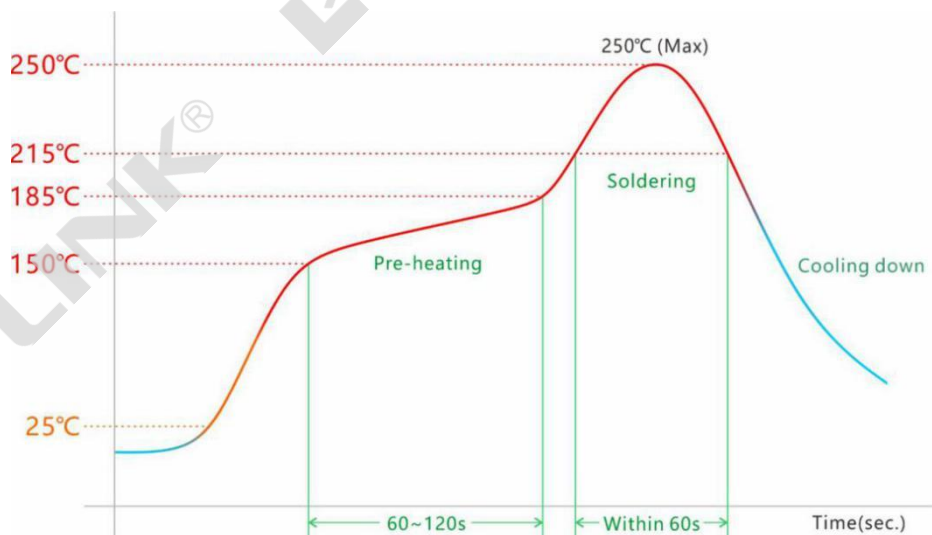

Please use the reflow within 2 times.  
Set up the highest temperature within 250°C.

## 8. Key Components Of Module

No.	Parts	Specification	Manufacturer	Note
1	Chipset	RTL8723BU-CG	Realtek	
2	PCB	BL-R8723BT1	Shen Zhen Tie Fa Technology limited	
			Guangdong KINGSHINE ELECTRONICS CO., LTD	
			Quzhou Sunlord Electronics Co., Ltd	
3	Crystal	40MHz-15pF-10ppm-2520	HARMONY ELECTRONICS CORP.	
			LUCKI CM ELECTRONICS CO., LTD	
			HOSONIC ELECTRONIC CO., LTD.	
			SHENZHEN KAIYUEXIANG ELECTRONICS CO., LTD	

## 9. Package and Storage Information

### 9.1 Package Dimensions

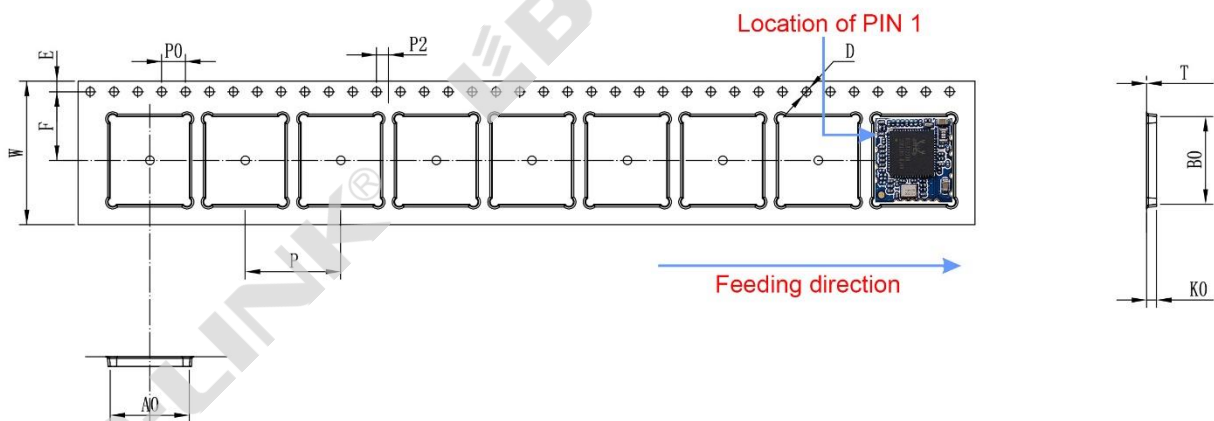

ITEM	W	A0	B0	K0	E	F	P	P0	P2	D	T
DIM	24.00±0.3	12.85±0.1	14.30±0.1	1.85±0.1	1.75±0.1	11.5±0.1	16.00±0.1	4.00±0.1	2.00±0.1	Ø1.5±0.1	0.30±0.05



## Package specification:

1. 2,000 modules per roll and 10,000 modules per box.
2. Outer box size: 37.5\*36\*29cm.
3. The diameter of the blue environment-friendly rubber plate is 13 inches, with a total thickness of 25.3mm (with a width of 21.3mm carrying belt).
4. Put 1 package of dry agent (20g) and humidity card in each anti-static vacuum bag.
5. Each carton is packed with 5 boxes.

## 9.2 Storage Conditions

### Absolute Maximum Ratings:

Storage temperature: -45°C to +85°C

Storage humidity: 10% to 95% RH (Non-Condensing)

### Recommended Storage Conditions:

Storage temperature: 5°C to +40°C

Storage humidity: 20% to 90% RH

Please use this Module within 12month after vacuum-packaged.

The Module shall be stored without opening the packing.

After the packing opened, the Module shall be used within 72hours.

When the color of the humidity indicator in the packing changed, the Module shall be baked before soldering.

Baking condition: 60°C, 24hours, 1time.

### ESD Sensitivity:

The Module is a static-sensitive electronic device.

Do not operate or store near strong electrostatic fields.

Take proper ESD precautions!