

## Features

- Ultra low leakage: nA level
- Operating voltage: 5V
- Low clamping voltage
- Complies with following standards:
  - IEC 61000-4-2 (ESD) immunity test
    - Air discharge:  $\pm 30\text{kV}$
    - Contact discharge:  $\pm 30\text{kV}$
  - IEC61000-4-5 (Lightning) 9A (8/20 $\mu\text{s}$ )
  - IEC61000-4-4 (EFT) 40A (5/50ns)
- RoHS Compliant

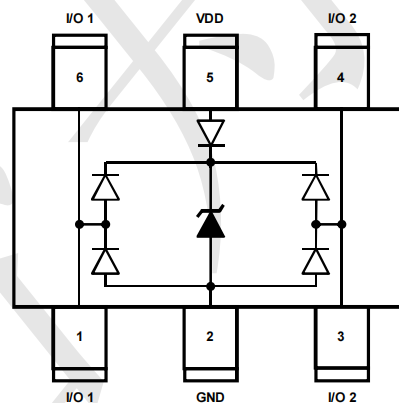
## Mechanical Characteristics

- Package: SOT23-6
- Lead Finish: Matte Tin
- Case Material: “Green” Molding Compound.
- UL Flammability Classification Rating 94V-0
- Moisture Sensitivity: Level 3 per J-STD-020
- Shipping Qty : 3000pcs/7Inch Tape & Reel

## Applications

- USB 2.0 power and data line
- Set-top box and digital TV
- Digital video interface (DVI)
- Notebook Computers
- SIM Ports
- 10/100 Ethernet

## Dimensions and Pin Configuration



**Marking: UL2Y**

**Absolute Maximum Ratings** (Tamb=25°C unless otherwise specified)

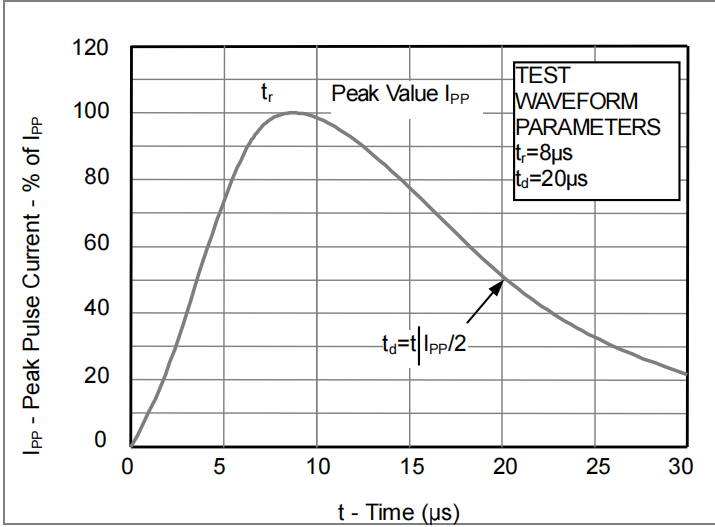
Parameter	Symbol	Value	Unit
Peak Pulse Power (8/20µs)	Ppk	150	W
Peak Pulse Current (8/20µs)	Ipp	9	A
ESD per IEC 61000-4-2 (Air)	VESD	±30	kV
ESD per IEC 61000-4-2 (Contact)		±30	
Operating Temperature Range	TJ	-55 to +125	°C
Storage Temperature Range	Tstg	-55 to +150	°C

**Electrical Characteristics** (TA=25°C unless otherwise specified)

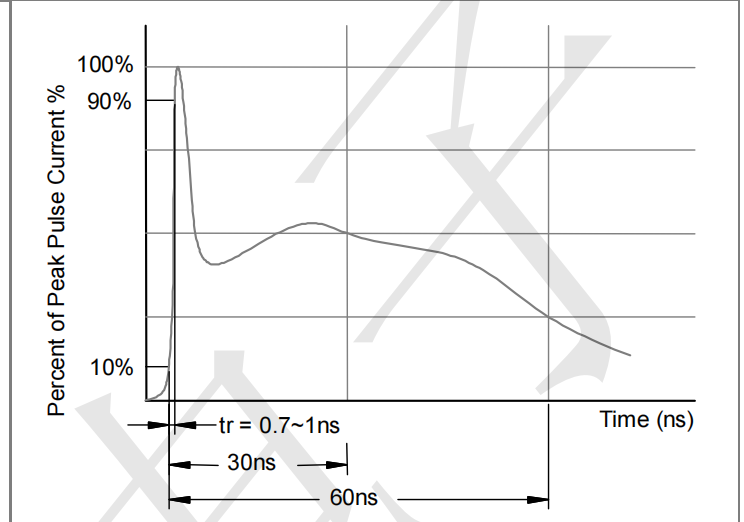
Parameter	Symbol	Min	Typ	Max	Unit	Test Condition
Reverse Working Voltage	VRWM			5	V	
Breakdown Voltage	VBR	6.5			V	IT = 1mA
Reverse Leakage Current	IR			0.08	uA	VRWM =5V
Clamping Voltage	VC			9	V	I <sub>PP</sub> = 1A (8 x 20µs pulse)
Clamping Voltage	VC			12	V	I <sub>PP</sub> = 9A (8 x 20us pulse)
Junction Capacitance	CJ		1.0	1.3	pF	VR = 0V, f = 1MHz (IO to GND)
Junction Capacitance	CJ		0.6		pF	VR = 0V, f = 1MHz (IO to IO)

**Typical Performance Characteristics ( $T_A=25^\circ\text{C}$  unless otherwise Specified)**

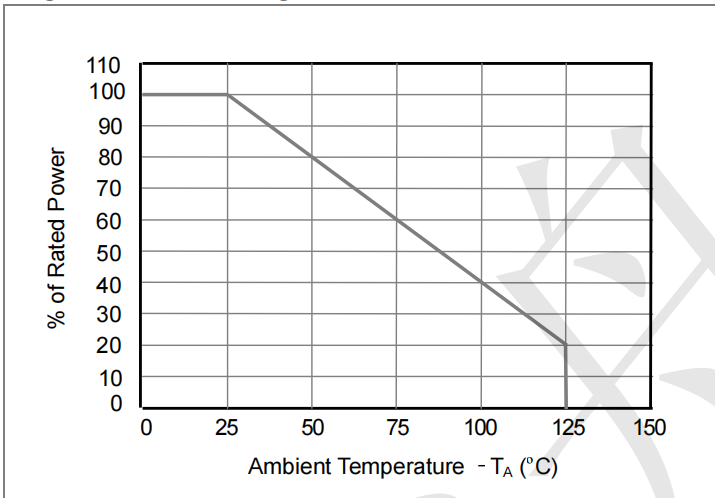
**Fig1. 8/20 $\mu\text{s}$  Pulse Waveform**



**Fig2. ESD Pulse Waveform (according to IEC 61000-4-2)**

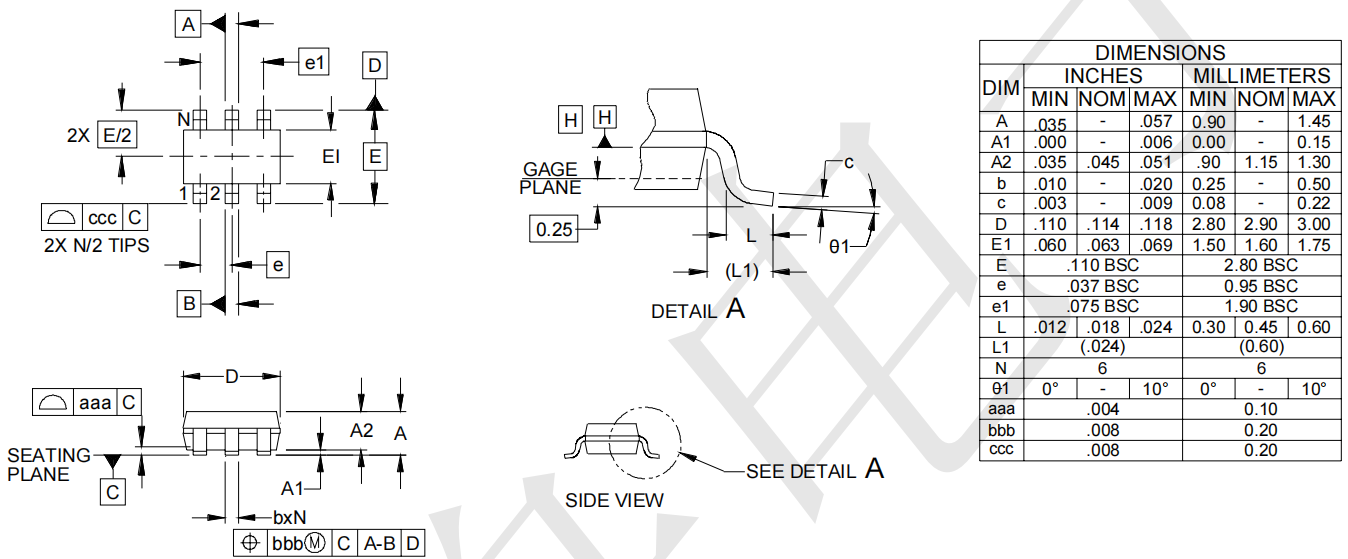


**Fig3. Power Derating Curve**





**Outline Drawing - SOT23-6**



**Land Pattern - SOT23-6**

