

RoHS Compliant

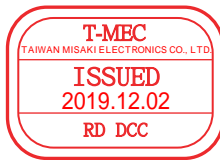

REVISIONS

Rev	DESCRIPTION	DATE	DRAWER	Rev	DESCRIPTION	DATE	DRAWER
A	Initial Drawing	2013.07.12	Catherine Lee	C	Update terminal and ESD pins coplanarity	2018.01.26	Landry Su
B	Update MODEL NO.	2017.06.30	Landry Su	D	Tolerance Modified	2019.11.29	Landry Su

SPECIFICATIONS

RATING	DC12V 50mA.	TIMING	
CONTACT RESISTANCE	100mΩ MAX.	OPERATION (TORQUE)	
INSULATION RESISTANCE	DC500V - 100MΩ MIN.	STROKE (ANGLE)	0.15±0.1 mm
WITHSTAND VOLTAGE	AC250V - 1 MINUTE.	LIFE	CYCLES
REMARKS:			

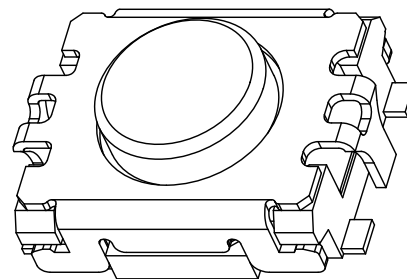
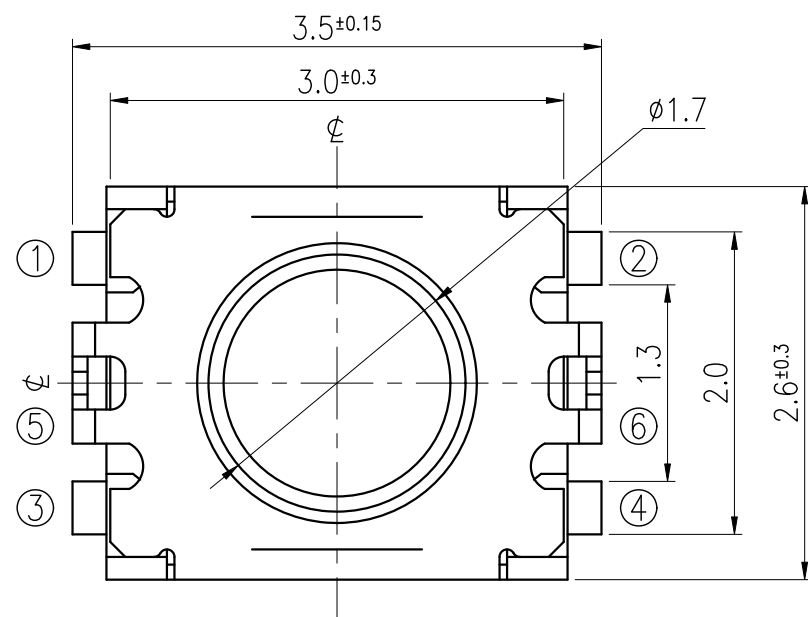

(terminal and ESD pins coplanarity of 0.1mm max)

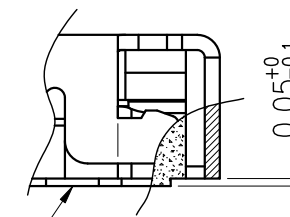

P.C.B MOUNTING FACE

TERMINALS DETAIL

SCHEMATIC

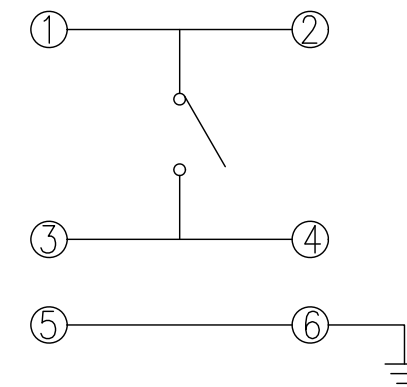

P.C.B LAYOUT

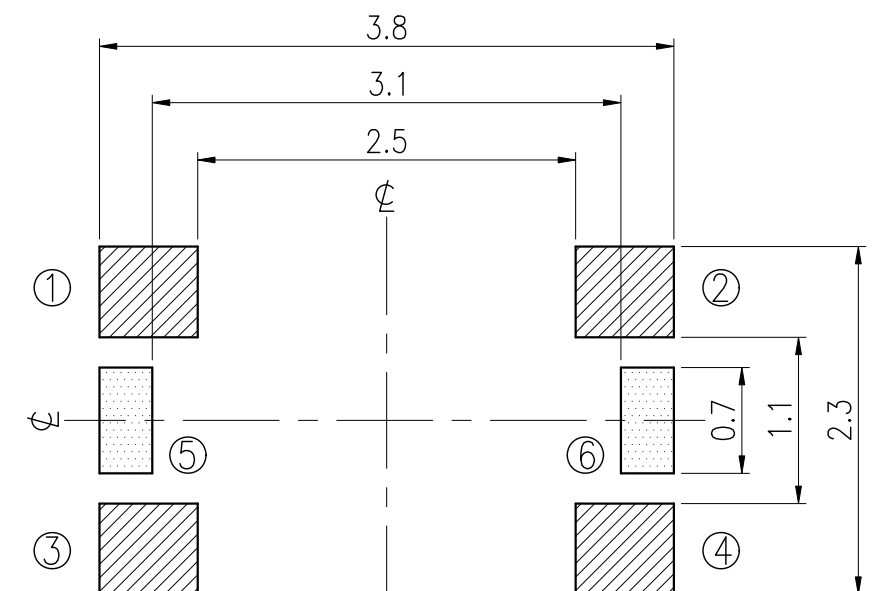

GROUND TERMINAL CAN BE EFFECTIVE EVEN IF NOT SOLDERED.

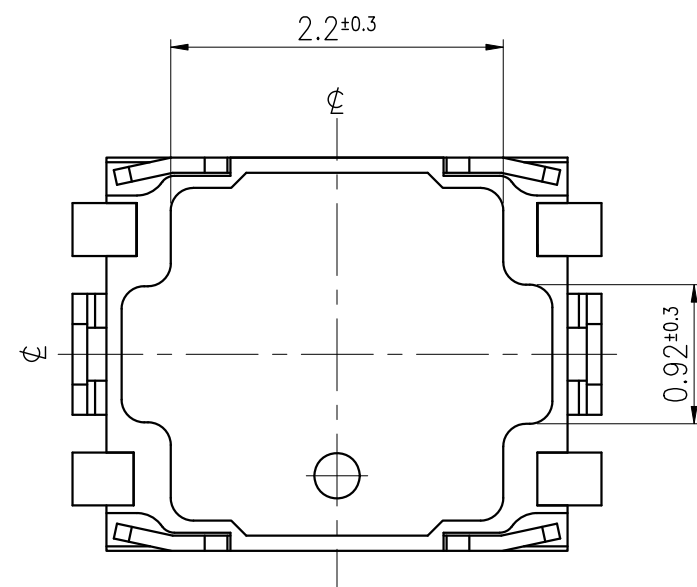
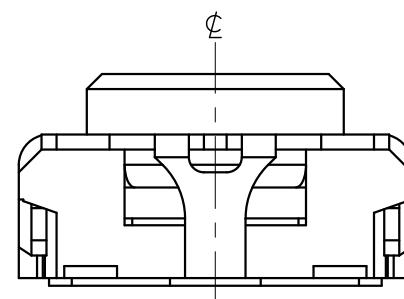
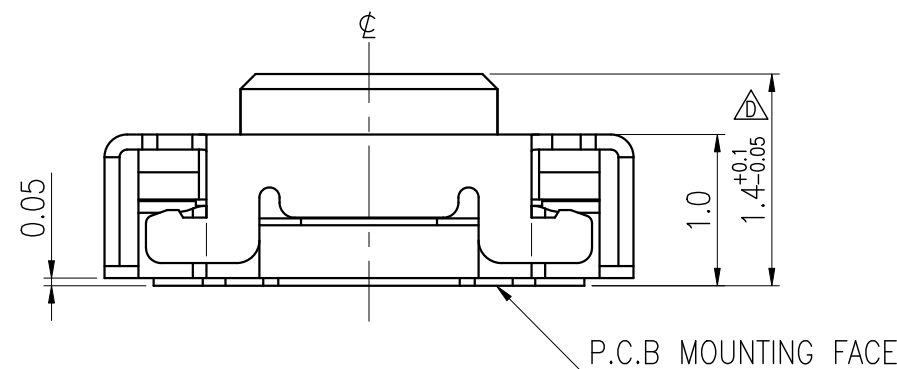

MODEL NO.	OPERATING FORCE	LIFE
NTC021-BA1G-A160TX	160±50 gf	500,000 CYCLES
NTC021-BA1G-A240TX	240±70 gf	200,000 CYCLES
NTC021-BA1G-A340T	340±70 gf	200,000 CYCLES
NTC021-BA1G-A450T	450±80 gf	200,000 CYCLES

TOLERANCES UNLESS OTHERWISE SPECIFIED ±0.1			SIGNATURES		DATE	MODEL
	UNIT	SCALE	DRAWER	Landry Su	2019.11.29	TITLE
	mm	20/1	CHECKED			TACT SWITCH
			REVIEWED			NO.
			APPROVALS	Qiuyuan Chuang	2019.11.29	SEE MODEL NO.

TAIWAN MISAKI ELECTRONICS CO., LTD.

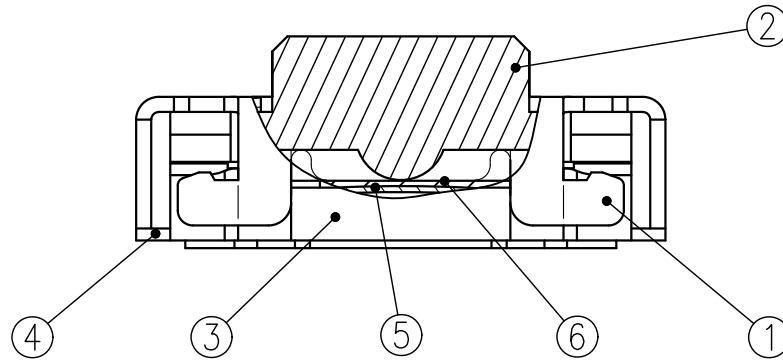

6	MYLAR	1	POLYIMIDE	
5	CONTACT PLATE	2	STAINLESS STEEL PLATE	Ag-PLATING
4	TERMINAL	4	COPPER ALLOY	Ag-PLATING OVER Ni PLATING
3	FRAME	1	LIQUID CRYSTAL POLYMER	BLACK
2	STEM	1	LIQUID CRYSTAL POLYMER	BLACK
1	COVER	1	STAINLESS STEEL PLATE	Matte Sn PLATING OVER Ni PLATING
NO.	PART NAME	Q'TY	MATERIAL	SPECIFICATION

				SIGNATURES	DATE	M O D E L
				DRAWN Catherine Lee	2014.01.07	TITLE TACT SWITCH
				CHK'D		NO. NTC021-BA1G-A160TX
				REV'D		
SYM	DESCRIPTION	DATE	APPROVED	APP'D <i>Dennis Hung</i>	2014.01.07	DWG NO. NTC021-02
TAIWAN MISAKI ELECTRONICS CO.,LTD.						

SPECIFICATIONS FOR TACT SWITCH

RoHS Compliant

Model:

1. Test condition:

Standard test conditions shall be 5~35°C in temperature, 45~85%RH in humidity and 86~106Kpa in atmospheric pressure. Should any doubt arise in judgment, tests shall be conducted at 20±2°C in temperature, 60~70% RH in Humidity and 86~106 kpa in atmospheric pressure.

2. Operating temperature range: -40 ~ +85°C

Preservative temperature range: -40 ~ +85°C

3. Construction:

3.1 Shape and dimension are subject to attached drawing regulation.

3.2 Appearance: Whole should be a good completion, no rust, no crack and good plating.

4. Rating: 12V D.C. , 50mA.

5. Electrical Performance:

No.	Items	Test conditions	Specifications
5.1	Contact Resistance	Shall be measure at 1kHz±200Hz (MAX. 20mV, MAX. 50mA.) or 1 A, 5V D.C. By voltage drop method.	100mΩ Max.
5.2	Insulation Resistance	Shall be measured by applying 500V D.C. Between all terminals and between the terminals and the frame for 1 minute ± 5 seconds.	100 MΩ Min.
5.3	Withstand Voltage	250V A.C. (50~60Hz 2mA) shall be applied between all terminals and between the terminals and the frame for 1 minute.	No dielectric breakdown shall be occurred.
5.4	Bounce	<p>Lightly striking the center of the stem at a rate encountered in normal use (3 to 4 operations per sec.)</p> <div style="text-align: center;"> </div>	<p>ON: 10m sec Max. OFF: 10m sec Max.</p>

			APPROVED BY	REVIEWED BY	CHECKED BY	DESIGNED BY	SPEC NO.
			<i>Dennis Hung</i>			Catherine Lee	SE-TC60N
			2012.09.12			2012.09.12	PAGINATE
A	NEW RELEASE						
SYM	DISCRIPTION	DATE					1/5

SPECIFICATIONS FOR TACT SWITCH

RoHS Compliant

6. Mechanical Performance:

No.	Items	Test conditions	Specifications
6.1	Operating Force	<p>Placing the switch such that the direction of switch operation is vertical and then gradually increasing the load applied to the center of the stem, the maximum load required for the switch to come to a stop shall be measured.</p>	<p>Push force: 160±50 gf</p> <p>Return force: 10 gf min.</p>
6.2	Travel	<p>Placing the switch such that the direction of switch operation is vertical and then applying a below static load to the center of the stem, the travel distance for the switch to come to a stop shall be measured.</p>	0.15 ± 0.1 mm.

			APPROVED BY	REVIEWED BY	CHECKED BY	DESIGNED BY	SPEC NO.
			<i>Dennis Hung</i>			Catherine Lee	SE-TC60N
			2012.09.12			2012.09.12	PAGINATE
A	NEW RELEASE						
SYM	DISCRIPTION	DATE					2/5

SPECIFICATIONS FOR TACT SWITCH

RoHS Compliant

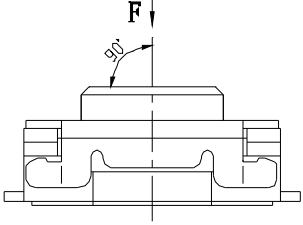
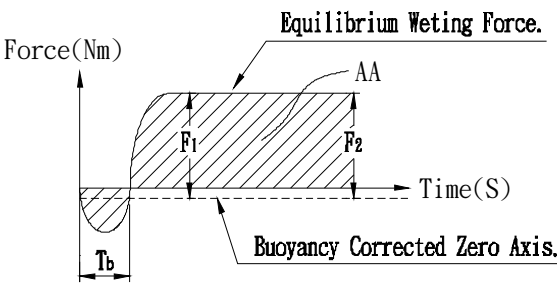
No.	Items	Test conditions	Specifications										
6.3	Push Strength	Placing the switch such that the direction of switch operation is vertical and then a below station load shall be applied in the direction of stem operation. 3kgf for 15seconds 	No damage. (Electrical and mechanical)										
6.4	Solderability	Test Temperature : 235 ± 5°C Immersion Angle : 90° Immersion Speed : 1 mm/sec. Immersion Depth : 0.1mm Dwell Time : 5 seconds  <table border="1" style="margin-top: 10px; width: 100%; border-collapse: collapse;"> <thead> <tr> <th style="width: 15%;">Para.</th> <th>Criteria</th> </tr> </thead> <tbody> <tr> <td>Tb</td> <td>≤ 1 second</td> </tr> <tr> <td>F1</td> <td>50% of maximum theoretical wetting force at or before two seconds</td> </tr> <tr> <td>F2</td> <td>No less than 90% of the F1 Value</td> </tr> <tr> <td>AA</td> <td>Area calculated using sample buoyancy and 50% maximum theoretical force</td> </tr> </tbody> </table>	Para.	Criteria	Tb	≤ 1 second	F1	50% of maximum theoretical wetting force at or before two seconds	F2	No less than 90% of the F1 Value	AA	Area calculated using sample buoyancy and 50% maximum theoretical force	Conform to the criteria in the left table.
Para.	Criteria												
Tb	≤ 1 second												
F1	50% of maximum theoretical wetting force at or before two seconds												
F2	No less than 90% of the F1 Value												
AA	Area calculated using sample buoyancy and 50% maximum theoretical force												

		APPROVED BY	REVIEWED BY	CHECKED BY	DESIGNED BY	SPEC NO.
		<i>Dennis Hung</i>			Catherine Lee	SE-TC60N
		2012.09.12			2012.09.12	PAGINATE
A	NEW RELEASE					
SYM	DISCRIPTION	DATE				3/5

SPECIFICATIONS FOR TACT SWITCH

RoHS Compliant

No.	Items	Test conditions	Specifications
6.5	Solder Heat Resistance	<p>(1) Manual soldering temperature: Temperature: 350°C Max. Time: 3 Sec. Max.</p> <p>(2) Reflow Soldering: Number of reflow pass: 2 cycles.</p> <div style="text-align: center;"> </div>	<p>Shall be free from pronounced deforming in appearance.</p> <p>Item 5.1~5.4 shall be satisfied.</p> <p>Item 6.1~6.2 shall be satisfied.</p>

7. Weather Performance:

No.	Items	Test conditions	Specifications
7.1	Humidity Test	<p>(1) Temperature: 60±2°C.</p> <p>(2) Relative humidity: 90~95%</p> <p>(3) Duration of test: 500 Hour.</p> <p>(4) Take off drop water.</p> <p>(5) Standard conditions after test: 1 Hour.</p>	<p>Contact resistance: 1Ω Max</p> <p>Item 5.2~5.4 shall be satisfied.</p> <p>Item 6.1~6.2 shall be satisfied.</p>
7.2	Heat Test	<p>(1) Temperature: 85±2°C.</p> <p>(2) Duration of test: 500 Hour.</p> <p>(3) Standard conditions after test: 1 Hour.</p>	
7.3	Cold Test	<p>(1) Temperature: -40±2°C.</p> <p>(2) Duration of test: 500 Hour.</p> <p>(3) Take off drop water.</p> <p>(4) Standard conditions after test: 1 Hour.</p>	

			APPROVED BY	REVIEWED BY	CHECKED BY	DESIGNED BY	SPEC NO.
			<i>Dennis Hung</i>			Catherine Lee	SE-TC60N
			2012.09.12			2012.09.12	PAGINATE
A	NEW RELEASE						
SYM	DISCRIPTION	DATE					4/5

SPECIFICATIONS FOR TACT SWITCH

RoHS Compliant

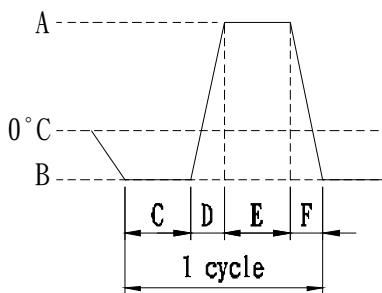
No.	Items	Test conditions	Specifications
7.4	Temperature cycle	(1) Test cycle: 20 cycles. (2) Standard conditions after test: 1 Hour.  <div style="margin-left: 200px;"> A: +85±2°C B: -40±2°C C: 2 hour D: 1 hour E: 2 hour F: 1 hour </div>	Contact resistance: 1Ω Max Item 5.2~5.4 shall be satisfied. Item 6.1~6.2 shall be satisfied.

8. Durability:

No.	Items	Test conditions	Specifications
8.1	Life Test	(1) 5V D.C. , 5mA Resistance load. (2) Operating speed: 120 cycles/minute. (2) Push force: Maximum value of operation force. (3) Operation number: 500,000 times.	Contact Resistance: 2Ω MAX. Bounce: 20m sec Max.(ON,OFF) Operating Force: Within ±30% of specifications. Item 5.2 shall be satisfied. Item 6.2 shall be satisfied.

			APPROVED BY	REVIEWED BY	CHECKED BY	DESIGNED BY	SPEC NO.
			<i>Dennis Hung</i>			Catherine Lee	SE-TC60N
			2012.09.12			2012.09.12	PAGINATE
A	NEW RELEASE						
SYM	DISCRIPTION	DATE					5/5

THE PACKING SPECIFICATIONS

RoHS Compliant

1. STRUCTURE AND MATERIALS

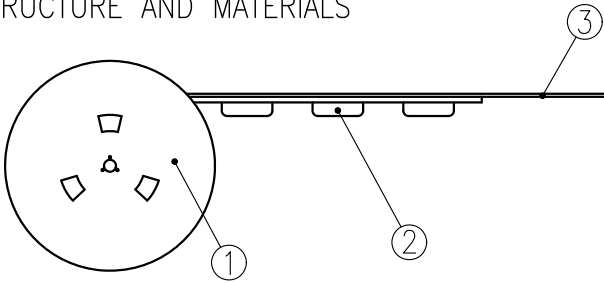

③	COVER TAPE	POLYESTER
②	CARRIER TAPE	POLYSTYRENE
①	REEL	POLYSTYRENE
NO.	PARTS NAME	MATERIALS

- PACKAGING QUANTITY : 9,500 PCS/REEL
- MORE THAN 10 EMPTY POCKETS SHOULD BE REMAINED AT BOTH ENDS OF THE CARRIER TAPE FOR EACH REEL.
- SHORTAGE LESS THAN 10 PCS A REEL IS ACCECTABLE BUT MORE THAN 3 RUNNING POCKETS SHORTAGE IS NOT ALLOWED.
- STRIPPING STRENGTH OF COVER TAPE IS BETWEEN 10 gf TO **130** gf AND STRIPPING ANGLE SHOULD BE WITHIN 165° ~ 180 °.
- THE PRODUCT IN THE POCKET OF CARRIER TAPE SHOULD BE PLACED IN A SPECIFIED CORRECT POSITION.
- TAPE AND REEL PER EIA-481.
- DIMENSIONS :

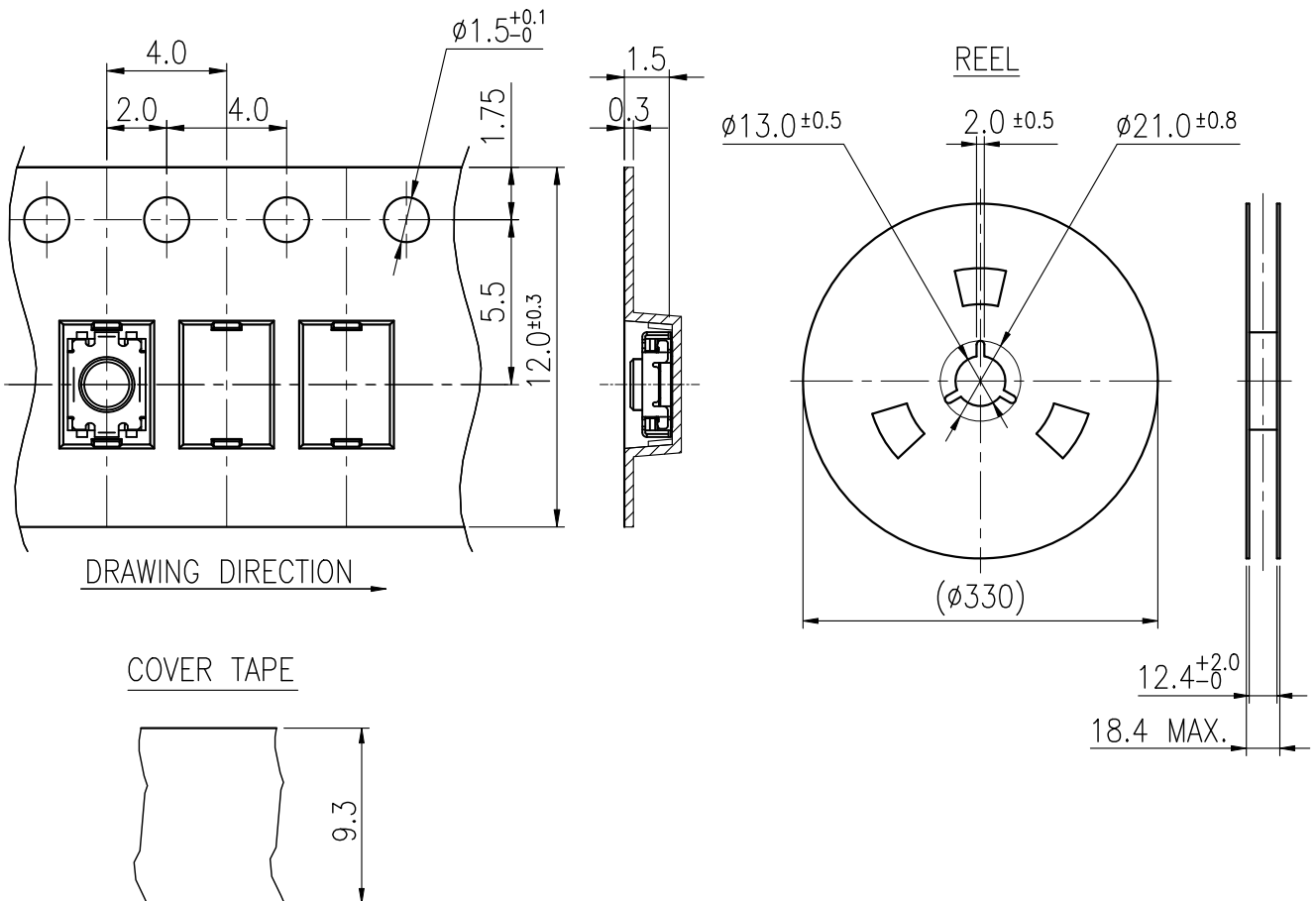
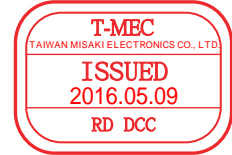

				APPROVED BY	REVIEWED BY	CHECKED BY	DESIGNED BY	MODEL NO.
							Catherine Lee	NTC021-BA1G-A 160 TX
							2014.01.07	PAGINATE.
								1/1
								SPEC NO.
								P-748
SYM	DISCRPTION	DATE	APPROVED					