

RoHS Compliant

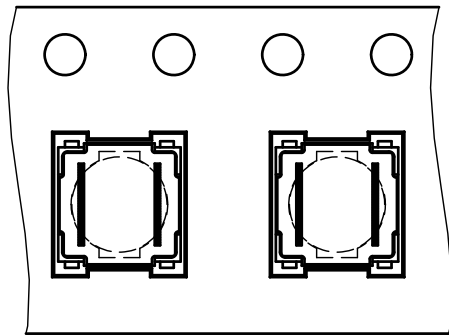

CARRIER TAPE

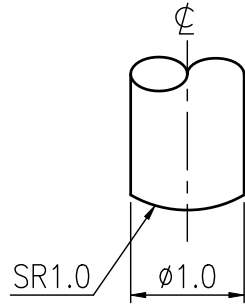

SHAPE OF KEYING TIP

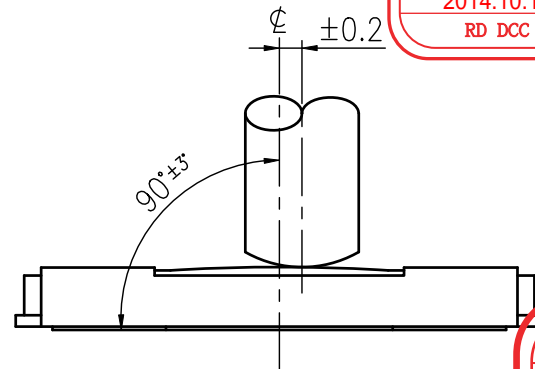

RESTRICTION IN OPERATION

T-MEC
TAIWAN MISAKI ELECTRONICS CO., LTD.
ISSUED
2014.10.15
RD DCC

T-MEC
作廢章
2015.05.11
文管中心 TW

REVISIONS							
Rev	DESCRIPTION	DATE	DRAWER	Rev	DESCRIPTION	DATE	DRAWER
A	Initial Drawing	2013.07.03	Ken Lin	C			
B	Change Drawing	2014.10.14	Jane Shen	D			

SPECIFICATIONS			
RATING	DC12V 50mA	TIMING	
CONTACT RESISTANCE	100mΩ MAX.	OPERATION (TORQUE)	260±50 gf $\triangle B$
INSULATION RESISTANCE	DC500V-100MΩ MIN.	STROKE (ANGLE)	0.2 $^{+0.15}$ mm
WITHSTAND VOLTAGE	AC250V-1 MINUTE	CONTACT RESISTANCE	2Ω MAX.
REMARKS:		(AFTER 200,000 CYCLES LIFE TEST)	

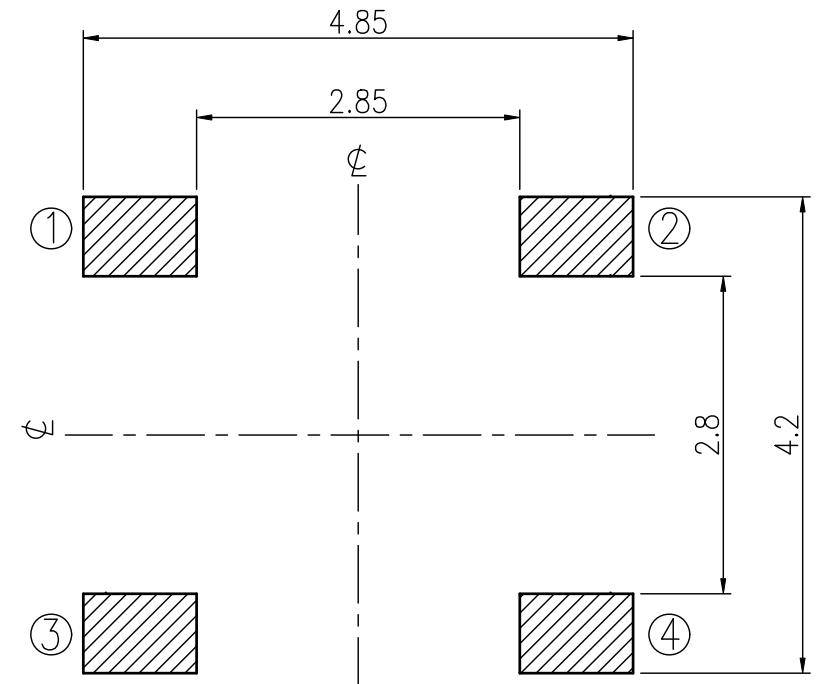
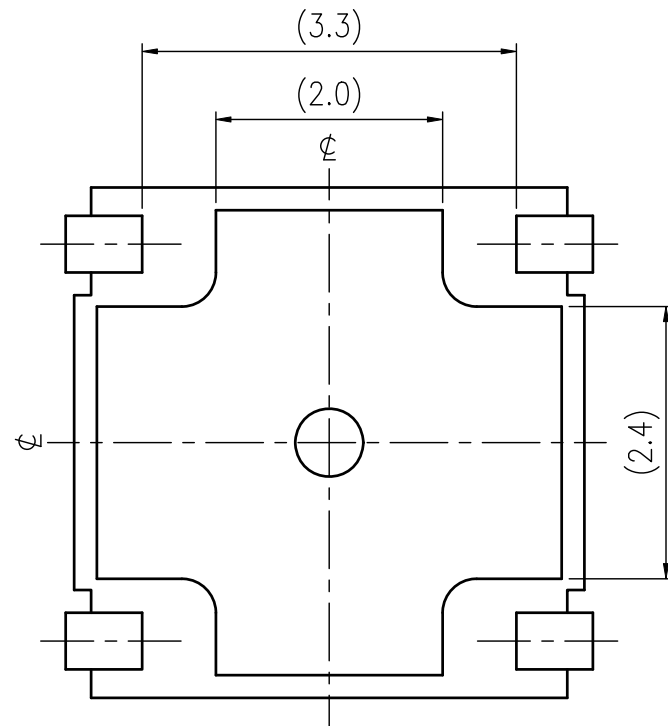
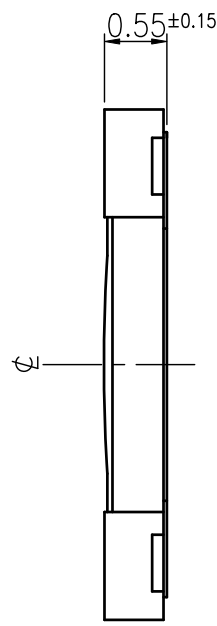
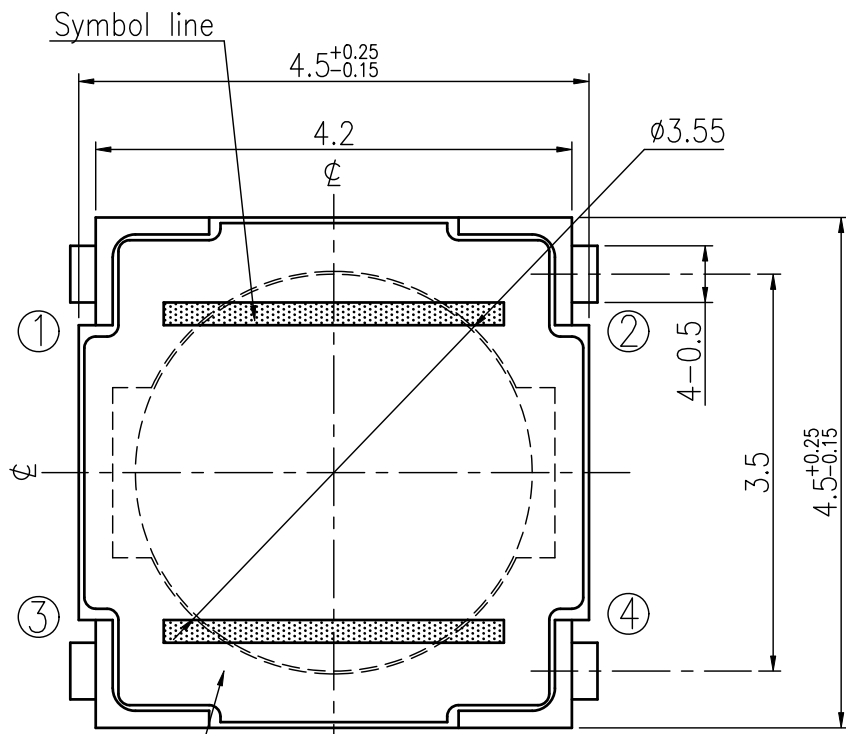

SCHEMATIC

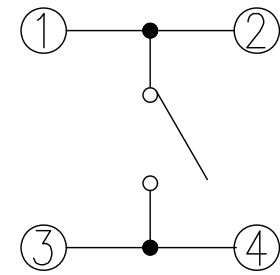

REFERENCE LAND FORM

TOLERANCES UNLESS OTHERWISE SPECIFIED ±0.1		SIGNATURES		DATE	MODEL	
☉	UNIT mm	SCALE 15/1	DRAWER	Jane Shen	2014.10.15	TITLE TACT SWITCH
			CHECKED	Jamie Li	2014.10.15	
☉	UNIT mm	SCALE 15/1	REVIEWED			NO. NTC033-XK1K-X260T
			APPROVALS	Dennis Hung	2014.10.15	

TAIWAN MISAKI ELECTRONICS CO., LTD.

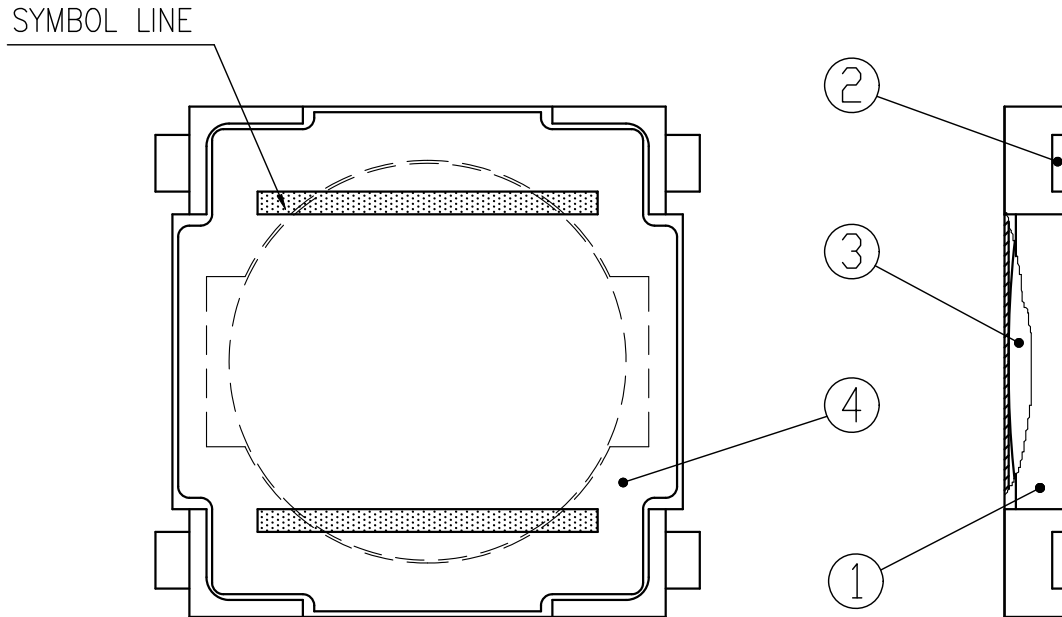

4	MYLAR	1	POLYIMIDE	
3	CONTACT PLATE	1	STAINLESS STEEL PLATE	Ag-PLATING
2	TERMINAL	4	COPPER ALLOY	Ag PLATING OVER Ni PLATING
1	FRAME	1	POLYAMIDE RESIN	BLUE COLOR
NO.	PART NAME	Q'TY	MATERIAL	SPECIFICATION

				SIGNATURES	DATE	M O D E L
				DRAWN Ken Lin	2013.06.20	TITLE TACT SWITCH
				CHK'D		NO. NTC033-XK1K-X260T
				REV'D		
SYM	DESCRIPTION	DATE	APPROVED	APP'D Dennis Hung	2013.06.20	DWG NO. TC033-22
TAIWAN MISAKI ELECTRONICS CO.,LTD.						

SPECIFICATIONS FOR TACT SWITCH

RoHS Compliant

Model:

1. Test condition:

Standard test conditions shall be 5~35°C in temperature, 45~85%RH in humidity and 86~106Kpa in atmospheric pressure. Should any doubt arise in judgment, tests shall be conducted at 20±2°C in temperature, 60~70% RH in Humidity and 86~106 kpa in atmospheric pressure.

2. Operating temperature range: -40 ~ +85°C

Preservative temperature range: Single condition: -40 ~ +85°C ; Taping condition: -20 ~ +60°C

3. Construction:

3.1 Shape and dimension are subject to attached drawing regulation.

3.2 Appearance: Whole should be a good completion, no rust, no crack and good plating.

4. Rating: 12V D.C. , 20mA.

5. Electrical Performance:

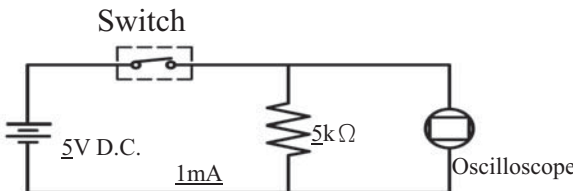
No.	Items	Test conditions	Specifications
5.1	Contact Resistance	Shall be measure at 1kHz±200Hz (MAX. 20mV, MAX. 50mA.) or <u>1</u> A, <u>5</u> V D.C. By voltage drop method.	<u>100mΩ</u> Max.
5.2	Insulation Resistance	Shall be measured by applying <u>500V</u> D.C. Between all terminals and between the terminals and the frame for 1 minute ± 5 seconds.	<u>100MΩ</u> Min.
5.3	Withstand Voltage	<u>250V</u> A.C. (50~60Hz 2mA) shall be applied between all terminals and between the terminals and the frame for 1 minute.	No dielectric breakdown shall be occurred.
5.4	Bounce	Lightly striking the center of the stem at a rate encountered in normal use (3 to 4 operations per sec.) <div style="text-align: center;">  <p style="font-size: small;">Switch 5V D.C. 1mA 5kΩ Oscilloscope</p> </div>	ON: <u>10m</u> sec Max. OFF: <u>10m</u> sec Max.

			APPROVED BY	REVIEWED BY	CHECKED BY	DESIGNED BY	SPEC NO.
			<i>Fred Chen</i> 2009-08-03	Jamie Li 2009.08.03	Max Chen 2009.08.03	Ken Lin 2009.08.03	SE-TC43N
A	NEW RELEASE						PAGINATE
SYM	DISCRIPTION	DATE					1/3

SPECIFICATIONS FOR TACT SWITCH

RoHS Compliant

6. Mechanical Performance:

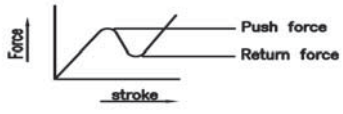
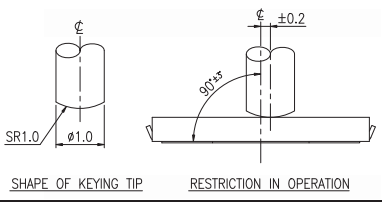
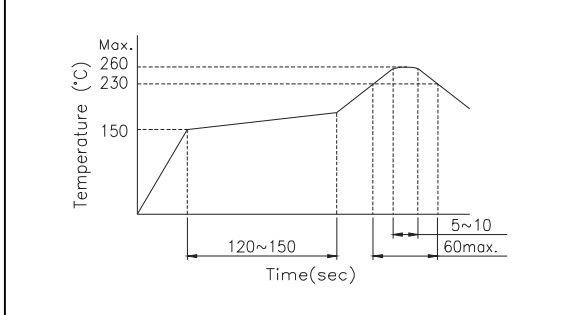
No.	Items	Test conditions	Specifications
6.1	Operating Force	Placing the switch such that the direction of switch operation is vertical and then gradually increasing the load applied to the center of the stem, the maximum load required for the switch to come to a stop shall be measured. <div style="text-align: center; margin-top: 10px;">  <p style="font-size: small;">Force</p> <p style="font-size: small;">stroke</p> <p style="font-size: small;">Push force</p> <p style="font-size: small;">Return force</p> </div>	$260 \pm 50 \text{ gf.}$
6.2	Travel	Placing the switch such that the direction of switch operation is vertical and then applying a below static load to the center of the stem, the travel distance for the switch to come to a stop shall be measured. <div style="text-align: center; margin-top: 10px;">  <p style="font-size: x-small;">SR1.0 $\phi 1.0$</p> <p style="font-size: x-small;">SHAPE OF KEYING TIP RESTRICTION IN OPERATION</p> </div>	$0.2 +0.15/-0.1 \text{ mm.}$
6.3	Control Strength	The static load of <u>3kgf</u> shall be applied on top of the terminal in every direction for 1 minute, in any direction on condition of once for one terminal.	Shall be free from extreme wobble, vent or electrical and mechanical abnormality. Not deformation of the appearance.
6.4	Solderability	Soldering temperature: $235 \pm 5^\circ\text{C}$. Soldering time: 2 ± 0.5 seconds.	75% or more of surface area of the portion immersed in solder shall be satisfied.
6.4	Solder Heat Resistance	(1) Manual soldering temperature: Temperature: 350°C Max. Time: 3 Sec. Max. (2) Reflow Soldering: Number of reflow pass: 2 cycles. <div style="text-align: center; margin-top: 10px;">  <p style="font-size: x-small;">Temperature (°C)</p> <p style="font-size: x-small;">Time(sec)</p> </div>	Shall be free from pronounced deforming in appearance. Of item 5.1~5.4 shall be satisfied. Of item 6.1~6.2 shall be satisfied.

			APPROVED BY	REVIEWED BY	CHECKED BY	DESIGNED BY	SPEC NO.
			<i>Fred Chen</i>	Jamie Li	Max Chen	Ken Lin	SE-TC43N
A	NEW RELEASE			2009.08.03	2009.08.03	2009.08.03	PAGINATE
SYM	DISCRIPTION	DATE	2009-08-03				2/3

SPECIFICATIONS FOR TACT SWITCH

RoHS Compliant

7. Weather Performance:

No.	Items	Test conditions	Specifications												
7.1	Humidity Test	(1) Temperature: 60±2°C. (2) Relative humidity: 90~95% (3) Duration of test: 500 Hour. (4) Take off a drop water. (5) Standard conditions after test: 1 Hour.	Contact resistance: <u>200mΩ</u> Max Of item 5.2~5.4 shall be satisfied. Of item 6.1~6.2 shall be satisfied.												
7.2	Heat Test	(1) Temperature: 85±2°C. (2) Duration of test: 500 Hour. (3) Standard conditions after test: 1 Hour.													
7.3	Cold Test	(1) Temperature: -40±2°C. (2) Duration of test: 500 Hour. (3) Take off a drop water. (4) Standard conditions after test: 1 Hour.													
7.4	Temperature cycle	(1) Test cycle: <u>5</u> cycles. (2) Standard conditions after test: 1 Hour.													
		<table border="1" style="width: 100%; border-collapse: collapse;"> <thead> <tr> <th style="width: 30%;"></th> <th style="width: 35%;">Temperature</th> <th style="width: 35%;">Duration of test</th> </tr> </thead> <tbody> <tr> <td rowspan="4" style="text-align: center;">1 cycles</td> <td style="text-align: center;">20±5°C</td> <td style="text-align: center;">1 Hour</td> </tr> <tr> <td style="text-align: center;">-40±2°C</td> <td style="text-align: center;">1 Hour</td> </tr> <tr> <td style="text-align: center;">20±5°C</td> <td style="text-align: center;">1 Hour</td> </tr> <tr> <td style="text-align: center;">85±2°C</td> <td style="text-align: center;">1 Hour</td> </tr> </tbody> </table>		Temperature	Duration of test	1 cycles	20±5°C	1 Hour	-40±2°C	1 Hour	20±5°C	1 Hour	85±2°C	1 Hour	
	Temperature	Duration of test													
1 cycles	20±5°C	1 Hour													
	-40±2°C	1 Hour													
	20±5°C	1 Hour													
	85±2°C	1 Hour													

8. Durability:

No.	Items	Test conditions	Specifications
8.1	Life Test (Without Load)	(1) Operating speed: 120 cycles/minute. (2) Push force: Maximum value of operation force. (3) Operation number: <u>200,000</u> times.	Contact Resistance: <u>2Ω</u> MAX. Operating Force: Within ±30% of specifications. Of item 5.2 shall be satisfied. Of item 6.2 shall be satisfied.

			APPROVED BY	REVIEWED BY	CHECKED BY	DESIGNED BY	SPEC NO.
			<i>Fred Chen</i>	Jamie Li	Max Chen	Ken Lin	SE-TC43N
				2009.08.03	2009.08.03	2009.08.03	PAGINATE
A	NEW RELEASE						
SYM	DISCRIPTION	DATE	2009-08-03				3/3

THE PACKING SPECIFICATIONS

RoHS Compliant

1. STRUCTURE AND MATERIALS

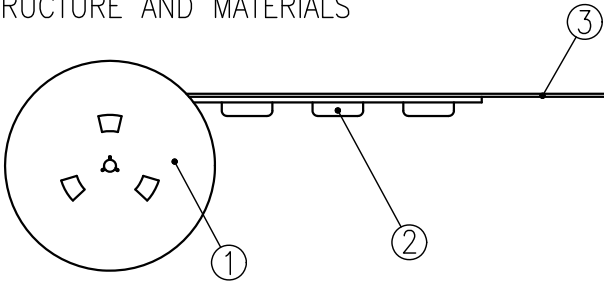

③	COVER TAPE	POLYESTER
②	CARRIER TAPE	POLYSTYRENE
①	REEL	POLYSTYRENE
NO.	PARTS NAME	MATERIALS

- PACKAGING QUANTITY : 7,000 PCS/REEL
- MORE THAN 10 EMPTY POCKETS SHOULD BE REMAINED AT BOTH ENDS OF THE CARRIER TAPE FOR EACH REEL.
- SHORTAGE LESS THAN 10 PCS A REEL IS ACCECTABLE BUT MORE THAN 3 RUNNING POCKETS SHORTAGE IS NOT ALLOWED.
- STRIPPING STRENGTH OF COVER TAPE IS BETWEEN 10 gf TO 70 gf AND STRIPPING ANGLE SHOULD BE WITHIN 165° ~ 180°.
- THE PRODUCT IN THE POCKET OF CARRIER TAPE SHOULD BE PLACED IN A SPECIFIED CORRECT POSITION.
- TAPE AND REEL PER EIA-481.
- DIMENSIONS :

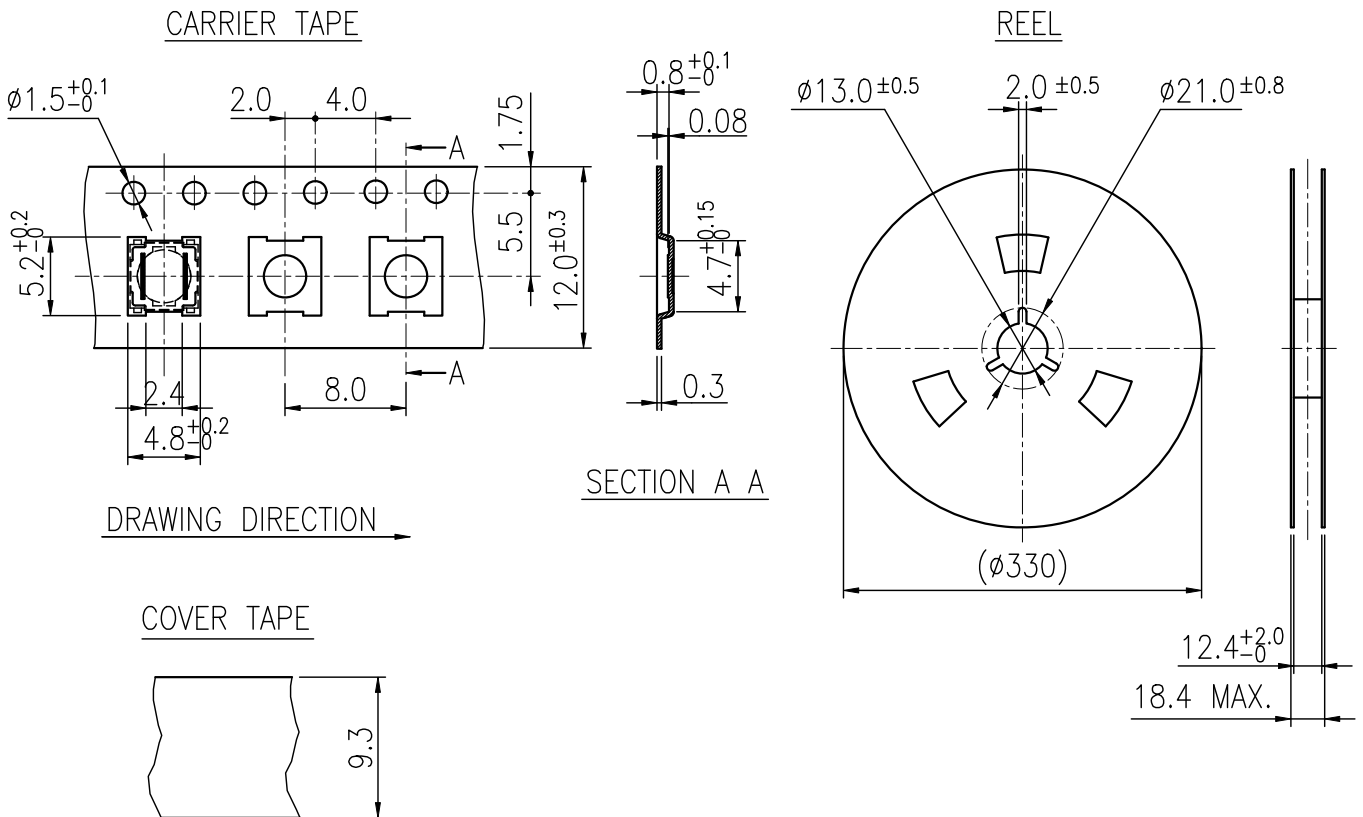

				APPROVED BY	REVIEWED BY	CHECKED BY	DESIGNED BY	MODEL NO.
				Dennis Hung			Ken Lin	NTC033-XK1K-X260T
				2013.01.23			2013.01.23	PAGINATE: 1/1
SYM	DISCRPTION	DATE	APPROVED					SPEC NO. P-656