

# SI2309

P-channel MOSFET



## P-Channel 60-V(D-S) MOSFET

V(BR)DSS	RDS(on)MAX	ID
-60V	160mΩ@ 10V	-2.0A

### FEATURE

※ TrenchFET Power MOSFET

### APPLICATION

- ※ Load Switch for Portable Devices
- ※ DC/DC Converter

### MARKING



### Equivalent Circuit

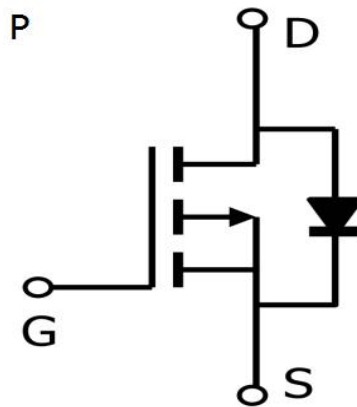

### SOT-23

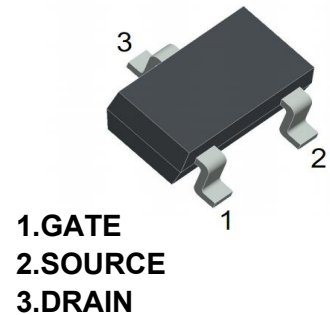

### Absolute Maximum Ratings ( Ta=25°C unless otherwise noted)

Parameter	Symbol	Value	Unit
Drain-Source Voltage	VDS	-60	V
Gate-Source Voltage	VGS	±20	V
Continuous Drain Current	ID	-2.0	A
Drain Current-Pulsed (note 1)	IDM	-10	A
Pulsed Drain Current	IDM	-8	A
Avalanche Current	IAS	-5	A
Power Dissipation	PD	1.25	W
Thermal Resistance from Junction to Ambient	RθJA	120	°C/W
Operating Junction and Storage Temperature Range	TJ,TSTG	-55~+150	°C

### Note :

※Surface Mounted on FR4 Board, t < 5 sec.

## MOSFET ELECTRICAL CHARACTERISTICS

### Static Electrical Characteristics (Ta = 25 °C Unless Otherwise Noted)

Parameter	Symbol	Test Condition	Min	Typ	Max	Unit
Drain-source breakdown voltage	V(BR)DSS	VGS = 0V, ID = -250μA	-60			V
Gate threshold voltage	VGS(th)	VDS = VGS, ID = -250μA	-1	-1.9	-3	V
Gate-source leakage current	IGSS	VDS = 0V, VGS = ±20 V			±100	nA
Zero gate voltage drain current	IDSS	VDS = -48V, VGS = 0V			-1	μA
	IDSS	VDS = -48V, VGS = 0V			-50	μA
On-state Drain Current	ID(ON)	VGS = -10V, VDS ≥ -4.5V	-6			A
Drain-source on-resistance	RDS(on)	VGS = -10V, ID = -2A		158	165	mΩ
Forward tranconductance	gFS	VDS = -4.5V, ID = -1A		1.9		S
Input capacitance	Ciss	VDS = -30V, VGS = 0V, f = 1MHz		210		pF
Output capacitance	Coss			28		pF
Reverse transfer capacitance	Crss			20		pF
Total Gate Charge	Qg	VDS = -30V, VGS = -10V, ID = -1.25 A		5.4	12	nC
Gate-Source Charge	Qgs			1.15		nC
Gate-Drain Charge	Qgd			0.92		nC
Turn-on Delay time	td(on)	VDD = -30V, RL = 6Ω, ID = -1A VGEN = -4.5V, RG = 6Ω		10.5	20	nS
Rise time	tr			11.5	20	nS
Turn-on Delay time	td(off)			15.5	30	nS
Fall time	tr			7.5	15	nS
Continuous Current	IS				-1.25	A
Pulsed Current	ISM				-8	A
Diode forward voltage	VSD	IS = -1.25A, VGS = 0V		-0.82	-1.25	V
Source-Drain Reverse Recovery Time	trr	IF = -1.25A Di/Dt = 100A/μs		30	55	ns

#### Note :

1. Repetitive Rating : Pulse width limited by maximum junction temperature.
2. Surface Mounted on FR4 Board, t < 5 sec.
3. Pulse Test : Pulse Width ≤ 300μs, Duty Cycle ≤ 2%.
4. Guaranteed by design, not subject to production testing.

**TYPICAL ELECTRICAL AND THERMAL CHARACTERISTICS**

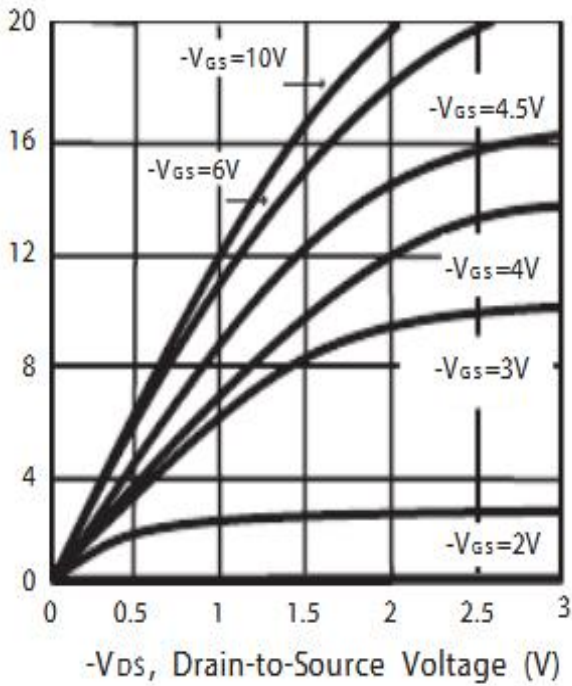

Figure 1. Output Characteristics

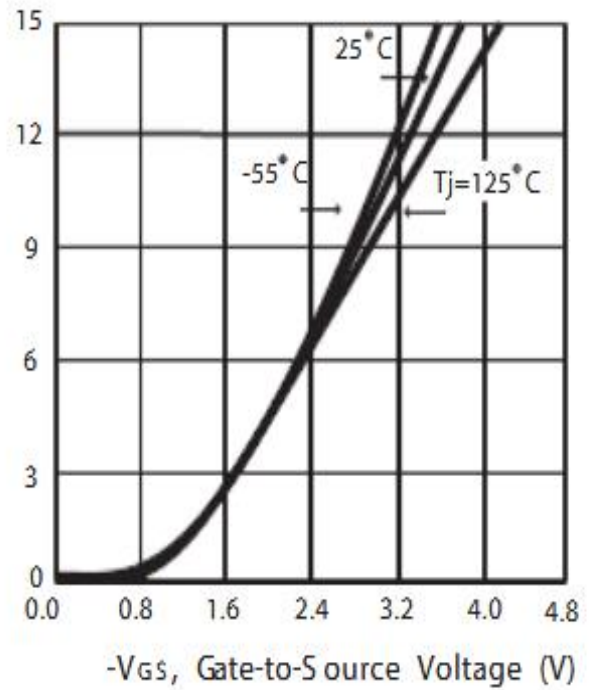

Figure 2. Transfer Characteristics

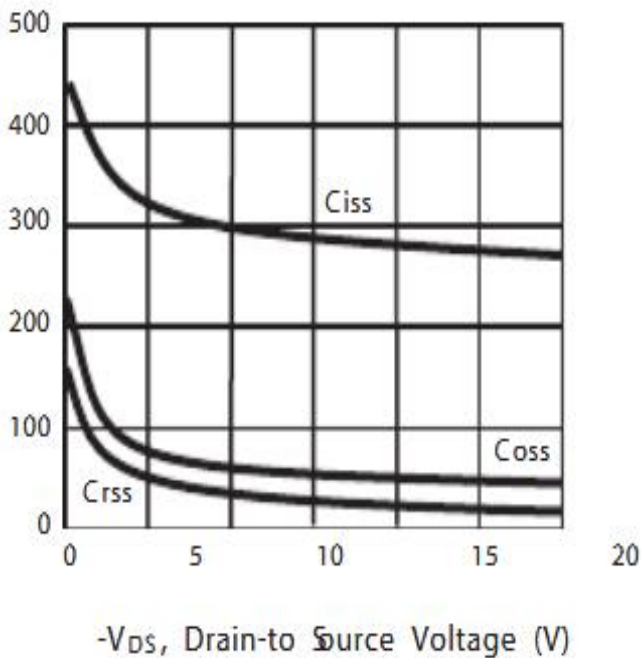

Figure 3. Capacitance

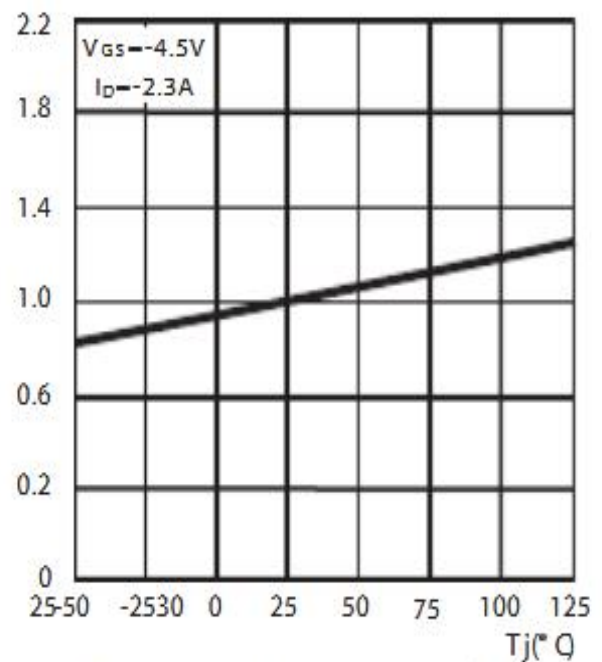
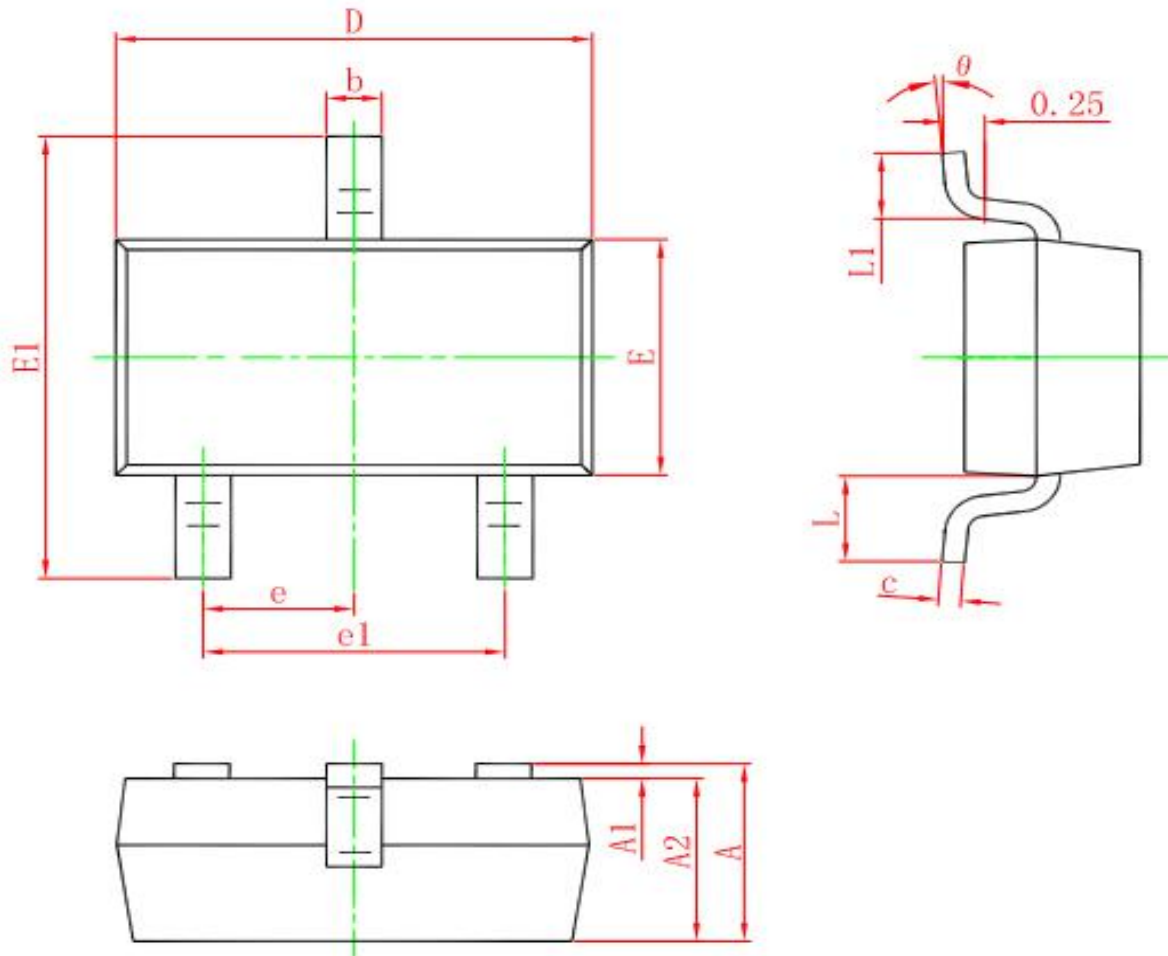

Figure 4. On-Resistance Variation with Temperature

## SOT-23 PACKAGE OUTLINE DIMENSIONS



Symbol	Dimensions In Millimeters		Dimensions In Inches	
	Min.	Max.	Min.	Max.
A	0.900	1.150	0.035	0.045
A1	0.000	0.100	0.000	0.004
A2	0.900	1.050	0.035	0.041
b	0.300	0.500	0.012	0.020
c	0.080	0.150	0.003	0.006
D	2.800	3.000	0.110	0.118
E	1.200	1.400	0.047	0.055
E1	2.250	2.550	0.089	0.100
e	0.950 TYP.		0.037 TYP.	
e1	1.800	2.000	0.071	0.079
L	0.550 REF.		0.022 REF.	
L1	0.300	0.500	0.012	0.020
theta	0°	8°	0°	8°