

P-Channel 20-V(D-S) MOSFET

| V(BR)DSS | RDS(on)MAX | ID |
|----------|--------------|-------|
| -20 V | 110mΩ@ -4.5V | -2.4A |
| | 150mΩ@ -2.5V | |

FEATURE

- TrenchFET Power MOSFET
- Supper high density cell design
- Extremely Low Threshold Voltage
- Excellent ON resistance for higher DC current

APPLICATION

- ※ Load Switch for Portable Devices
- ※ DC/DC Converter
- ※ Power Switch

MARKING

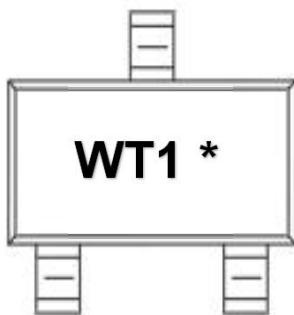

WT1 = Device Code
 * = Month (A~Z)

Equivalent Circuit

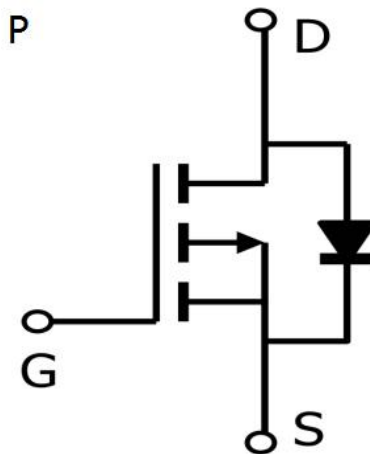

SOT-23

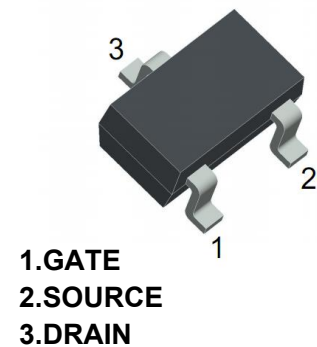

Maximum ratings (Ta=25°C unless otherwise noted)

| Parameter | Symbol | Value | Unit |
|---|--------|----------|------|
| Drain-Source Voltage | VDS | -20 | V |
| Gate-Source Voltage | VGS | ±8 | |
| Continuous Drain Current | ID | -2.4 | A |
| Pulsed Diode Current | IDM | -10 | |
| Power Dissipation | PD | 1.1 | W |
| Thermal Resistance from Junction to Ambient (t≤10s) | RθJA | 125 | °C/W |
| Operating Junction | TJ | 150 | °C |
| Storage Temperature | TSTG | -55~+150 | °C |

WPM2015-3/TR

MOSFET ELECTRICAL CHARACTERISTICS

Static Electrical Characteristics (Ta = 25 °C Unless Otherwise Noted)

| Parameter | Symbol | Test Condition | Min | Typ | Max | Unit |
|--|----------|---|------|------|------|------|
| Static | | | | | | |
| Drain-source breakdown voltage | V(BR)DSS | VGS = 0V, ID = -250μA | -20 | | | V |
| Gate-source threshold voltage | VGS(th) | VDS = VGS, ID = -250μA | -0.4 | | -1 | V |
| Gate-source leakage | IGSS | VDS = 0V, VGS = ±8V | | | ±100 | nA |
| Zero gate voltage drain current | IDSS | VDS = -16V, VGS = 0V | | | -1 | μA |
| Drain-source on-state resistancea | RDS(on) | VGS = -4.5V, ID = -2.7A | | 81 | 110 | mΩ |
| | | VGS = -2.5V, ID = -2A | | 103 | 150 | mΩ |
| Forward transconductancea | gfs | VDS = -4.5V, ID = -2.4A | | 10 | | S |
| Diode forward voltage | VSD | IS = -1A, VGS = 0V | | -0.8 | -1.5 | V |
| Dynamic | | | | | | |
| Input capacitance | Ciss | VDS = -10V, VGS = 0V, f = 1MHz | | 534 | | pF |
| Output capacitance | Coss | | | 62 | | pF |
| Reverse transfer capacitanceb | Crss | | | 54 | | pF |
| Total gate charge | Qg | VDS = -10V, VGS = -4.5V, ID = -2.4A | | 7.3 | | nC |
| Gate-source charge | Qgs | | | 1.25 | | nC |
| Gate-drain charge | Qgd | | | 1.2 | | nC |
| Gate resistance | Rg | f = 1MHz | 0.5 | | 3.2 | Ω |
| Switchingbtr | | | | | | |
| Turn-on delay time | td(on) | VDS = -10V RL = 3.5Ω, ID ≈ -1A, VGEN = -4.5V, Rg = 3Ω | | 8.0 | | ns |
| Rise time | tr | | | 6.4 | | ns |
| Turn-off delay time | td(off) | | | 41 | | ns |
| Fall time | tf | | | 7 | | ns |
| Drain-source body diode characteristicstr | | | | | | |
| Continuous Source-Drain Diode Current | IS | Tc = 25 °C | | | -1.2 | A |
| Pulsed Diode forward Curren | ISM | | | | -10 | A |

Note :

1. Repetitive Rating : Pulse width limited by maximum junction temperature.
2. Surface Mounted on FR4 Board, t < 10 sec.
3. Pulse Test : Pulse Width ≤ 300μs, Duty Cycle ≤ 2%.
4. Guaranteed by design, not subject to production testing.

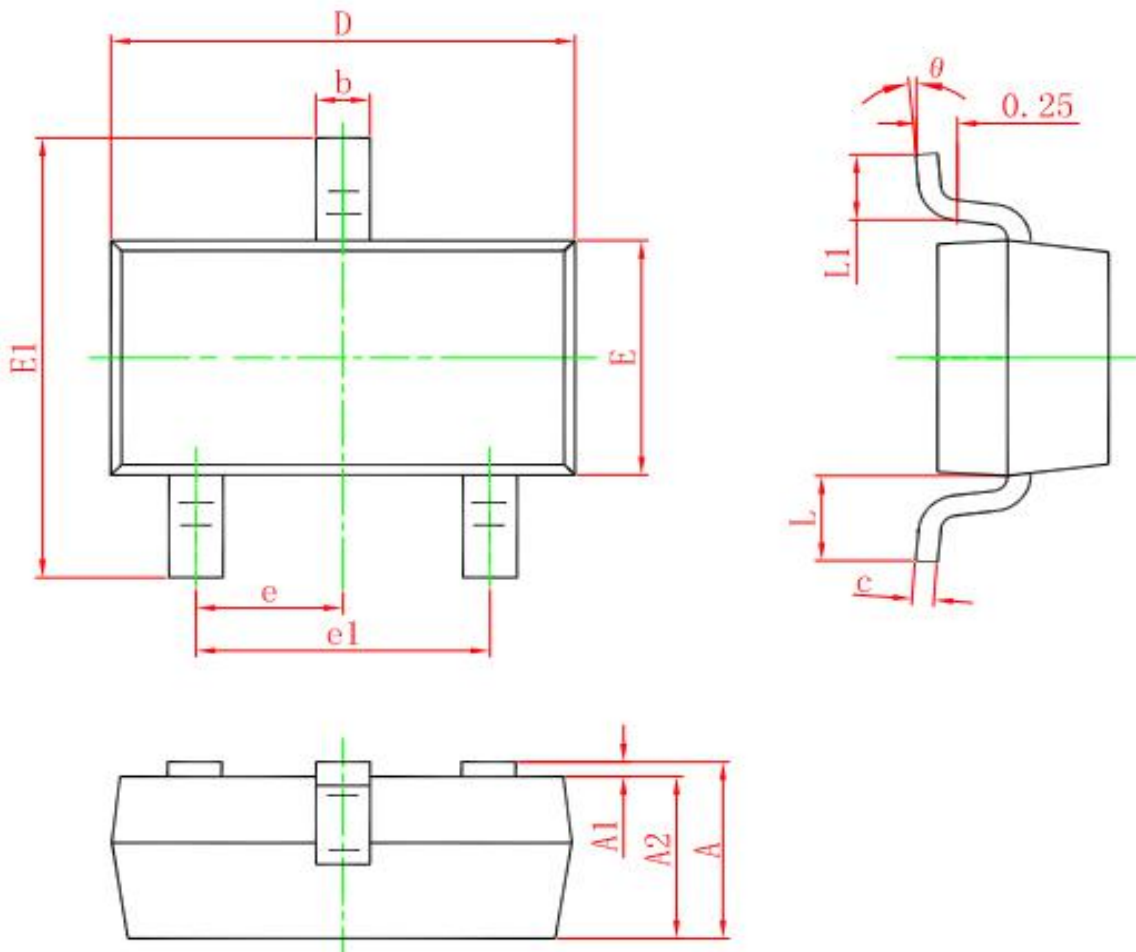
SOT-23 PACKAGE OUTLINE DIMENSIONS

| Symbol | Dimensions In Millimeters | | Dimensions In Inches | |
|----------|---------------------------|-------|----------------------|-------|
| | Min. | Max. | Min. | Max. |
| A | 0.900 | 1.150 | 0.035 | 0.045 |
| A1 | 0.000 | 0.100 | 0.000 | 0.004 |
| A2 | 0.900 | 1.050 | 0.035 | 0.041 |
| b | 0.300 | 0.500 | 0.012 | 0.020 |
| c | 0.080 | 0.150 | 0.003 | 0.006 |
| D | 2.800 | 3.000 | 0.110 | 0.118 |
| E | 1.200 | 1.400 | 0.047 | 0.055 |
| E1 | 2.250 | 2.550 | 0.089 | 0.100 |
| e | 0.950 TYP. | | 0.037 TYP. | |
| e1 | 1.800 | 2.000 | 0.071 | 0.079 |
| L | 0.550 REF. | | 0.022 REF. | |
| L1 | 0.300 | 0.500 | 0.012 | 0.020 |
| θ | 0° | 8° | 0° | 8° |