

300mA Low Noise Linear Regulator

Features

- Input Voltage Range: 2.5V to 6.5V
- Output Voltage Range:
 - Fixed Operation: 1.2V to 3.3V
- Maximum output current: 300mA
- Low Dropout Voltage: 152mV at 300mA
- Low Quiescent Current
- Low noise: $45\mu V_{RMS}$
- Output Voltage Accuracy: 2%
- Excellent Load and Line Transient Responses
- Thermal Shutdown and Over-Current Protection
- Stable with $1\mu F$ or Larger Ceramic Capacitor
- Operating Junction Temperature: $-40^{\circ}C$ to $+125^{\circ}C$
- Available package: SOT23-5

Description

The device is a fast transient, high PSRR, low quiescent current (IQ) and low dropout voltage linear regulator capable of sourcing 300mA current. The low 152mV dropout voltage at 300mA load improves efficiency and allows operation over a wide input voltage range. The low 155uA of operating supply current at 300mA load makes the device suitable for battery-operated portable equipment. The output voltage is fixed and spans from 1.2V to 3.3V.

The device also features short-circuit current limit and thermal shutdown protection, as well as automatic discharge function to quickly discharge V_{OUT} in the disabled states.

Applications

- Cellular Phones
- Laptop computers
- Portable Equipment
- Battery-Powered Systems
- High-Efficiency Linear Power Supplies

Typical Application Circuits

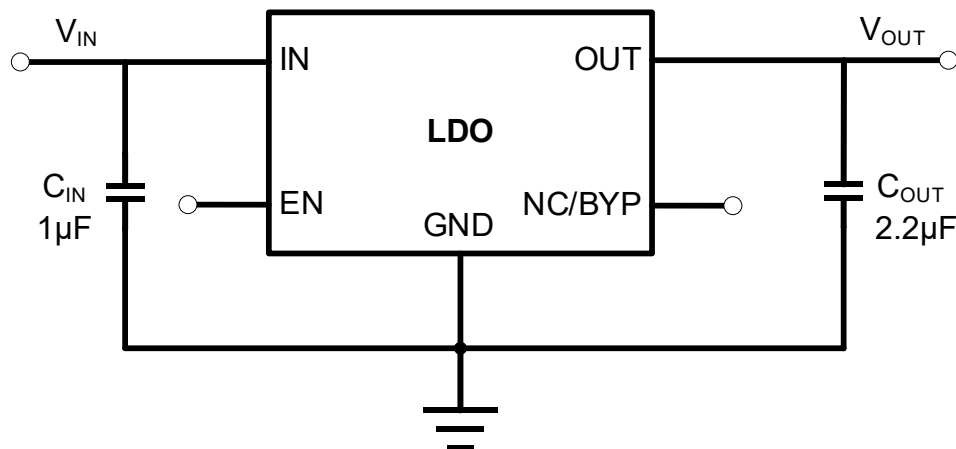

Pin Configuration and Functions

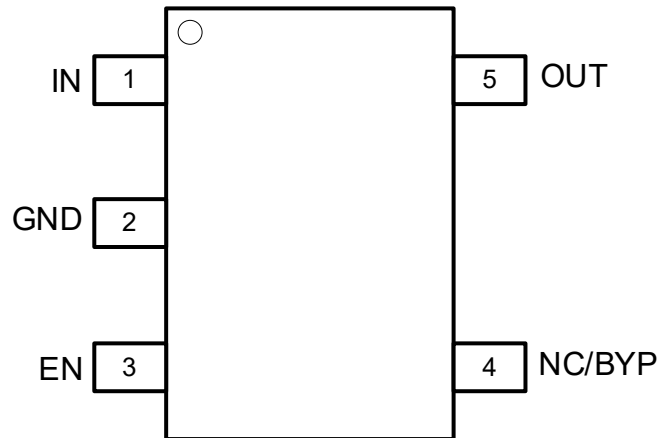

5-Pin SOT-23 (Top View)

Pin Descriptions

PIN Number	PIN Name	I/O	Function
1	IN	I	Input supply voltage pin. It is recommended to use a 1 μ F or larger ceramic capacitor from IN pin to ground to get a good power supply decoupling.
2	GND	-	Ground.
3	EN	I	Enable Pin. Drive EN high to turn on the regulator. Drive EN low to turn off the regulator.
4	NC/BYP	-	Do not connect (NC) or Connect a 10nF to ground to reduce output noise (BYP).
5	OUT	O	Regulator output voltage pin. A 2.2 μ F or larger ceramic capacitor from OUT to ground is required to ensure regulator stability.

Ordering Information

DEVICE	PACKAGE TYPE	OUTPUT VOLTAGE	PACKING OPTION
ADP150AUJZ-1.8-R7	SOT23-5	1.8V	Tape and Reel, 3000
ADP150AUJZ-2.5-R7	SOT23-5	2.5V	Tape and Reel, 3000
ADP150AUJZ-2.8-R7	SOT23-5	2.8V	Tape and Reel, 3000
ADP150AUJZ-3.0-R7	SOT23-5	3.0V	Tape and Reel, 3000
ADP150AUJZ-3.3-R7	SOT23-5	3.3V	Tape and Reel, 3000

Electrical Specifications

Absolute Maximum Ratings

Parameter	Symbol	Value	Unit
IN, OUT and EN Pins	IN, OUT and EN	-0.3 to 7	V
Storage temperature range	T _{STG}	-65 to +150	°C
Output current	I _{OUT}	Internally Limited	mA

Notes:

1. Exposure of the device under conditions beyond the limits specified by Maximum Ratings for extended periods may cause permanent damage to the device and affect product reliability. These conditions represent a stress rating only, and functional operations of the device at these or any other conditions above the operational limits noted in this specification is not implied.

ESD Ratings

		Value	Unit
V _{ESD}	Electrostatic Discharge	HBM (Human Body Model)	3000
		CDM (Charge Device Model)	1000

Recommended Operation Conditions

Over operating temperature range unless otherwise noted

Parameter	Symbol	Min	Max	Unit
Input Supply Voltage	V _{IN}	2.5	6.5	V
Enable Input Voltage	EN	0	V _{IN}	V
Output Voltage	V _{OUT}	1.2	4.5	V
Output Capacitance	C _{OUT}	1	47	μF
Output Current	I _{OUT}	0	300	mA
Operating Junction Temperature	T _J	-40	125	°C

Thermal Information

Package	R _{θJA}	Unit
SOT23-5	205	°C/W

Electrical Characteristics

$V_{IN} = 2.5V$ or $V_{IN} = V_{OUT} + 1V$ (whichever is greater), $I_{OUT} = 1mA$, $C_{OUT} = 2.2\mu F$, typical values are at $T_A = 25^\circ C$ unless otherwise noted

Parameter	Symbol	Test Conditions	Min	Typ	Max	Unit
Input Voltage	V_{IN}		2.5	-	6.5	V
Output Voltage Accuracy		$0.1mA \leq I_{OUT} \leq 300mA$	-2.0	0	2.0	%
GND Pin Current	I_{GND}	$V_{IN} = 2.5V$, No Load		82		μA
		$V_{IN} = 2.5V$, $I_{OUT} = 300mA$		158		μA
Shutdown Current	I_{SHDN}	$V_{IN} = 2.5V$, $V_{EN} = 0V$		2.3		μA
Dropout Voltage	V_{DO}	$V_{OUT} = 3.3V$, $I_{OUT} = 300mA$		152		mV
Output Current Limit	I_{LIM}	$V_{OUT} = 0V$	300			mA
Line Regulation	$\Delta V_{OUT(LINE)}$	$V_{IN} = V_{OUT} + 1V$ to 6.5V		0.05		mV/V
Load Regulation	$\frac{\Delta V_{OUT}}{(V_{OUT} \Delta I_{OUT})}$	$V_{IN} = 6V$, $I_{OUT} = 1mA$ to 300mA		0.3		%/A
EN pin low-level input voltage (device disabled)	$V_{IL(EN)}$				0.5	V
EN pin high-level input voltage (device enabled)	$V_{IH(EN)}$		1.6			V
EN PIN Leakage Current	I_{EN}	$V_{EN} = 6.5V$		0.8		μA
Power Supply Ripple Rejection	PSRR	$f = 1kHz$, $V_{OUT} = 3.3V$, $I_{OUT} = 300mA$		64		dB
Output Noise Voltage	V_N	BW = 10Hz to 100kHz, $C_{BYP} = 10nF$, $C_{OUT} = 2.2\mu F$, $V_{OUT} = 1.8V$, $I_{OUT} = 300mA$		45		μV
Thermal Shutdown Temperature	TSD			160		$^\circ C$
Thermal Shutdown Hysteresis	T_{HYS}			20		$^\circ C$

Typical Characteristics

$C_{IN} = 1\mu F$, $C_{OUT} = 2.2\mu F$, $I_{OUT} = 300mA$, $T_A = 25^\circ C$ unless otherwise noted

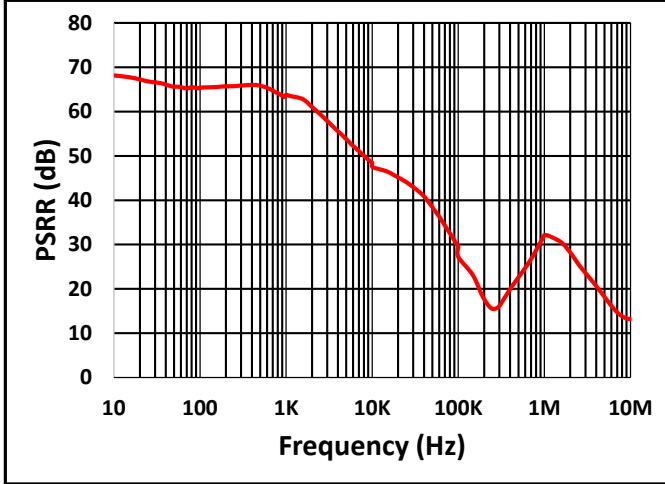

$V_{IN} = 6V$, $V_{OUT} = 3.3V$, $I_{OUT} = 300mA$, $C_{OUT} = 2.2\mu F$

Fig. 1 PSRR

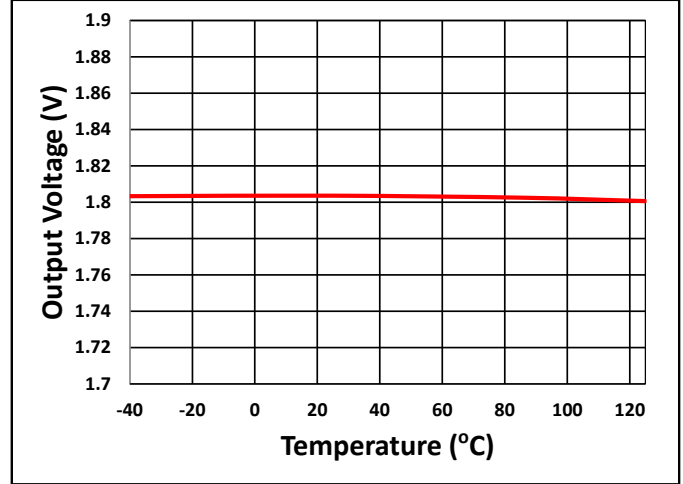

$V_{IN} = 6V$, $V_{OUT} = 3.3V$, $I_{OUT} = 0.1mA$

Fig. 2 Output Voltage vs Temperature

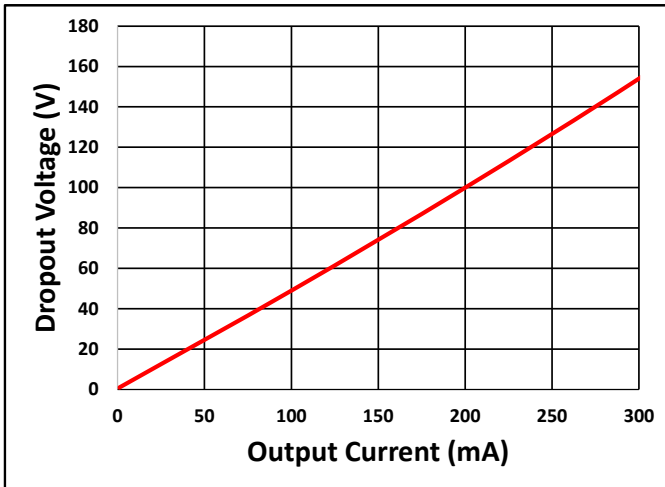

$V_{IN} = 6V$

Fig. 3 Dropout Voltage

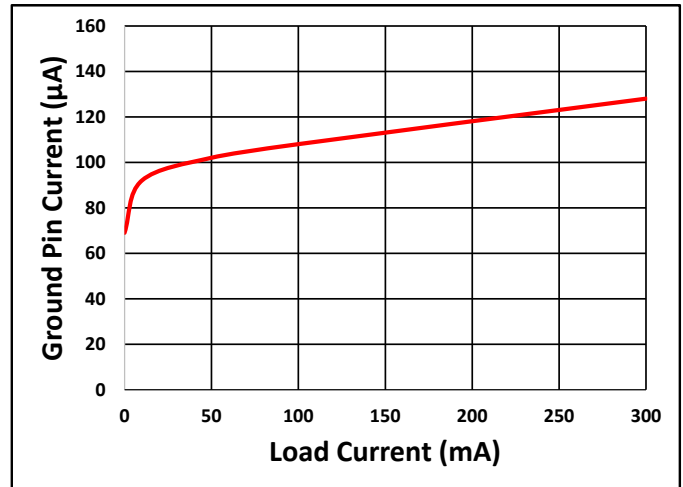

$V_{IN} = 2.5V$

Fig. 4 Ground Current vs Load Current

Functional Block Diagram

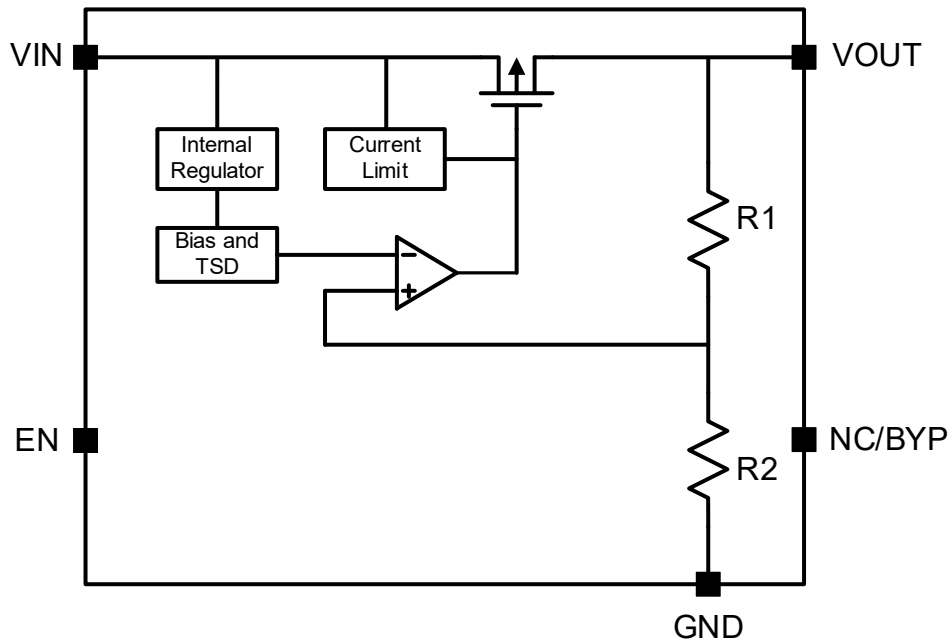

Feature Description

Enable

The enable pin for the LDO is active high. The device is enabled when the enable pin voltage is greater than $V_{IH(EN)}$ and disabled with the enable pin voltage less than $V_{IL(EN)}$. If independent control of chip enable is not needed, then connect the enable pin to the input. The LDO has an internal pulldown MOSFET that connects a discharge resistor from VOUT to ground when the device is disabled to actively discharge the output voltage.

Output Current Limit

When overload events happen, the output current is internally limited.

Undervoltage Lockout (UVLO)

The LDO uses an undervoltage lockout circuit to keep the output shut off until the internal circuitry is operating properly.

Thermal Protection

The LDO contains a thermal shutdown protection circuit to turn off the output current when excessive heat is dissipated in the LDO.

PACKAGE OUTLINE DIMENSIONS

SOT23-5

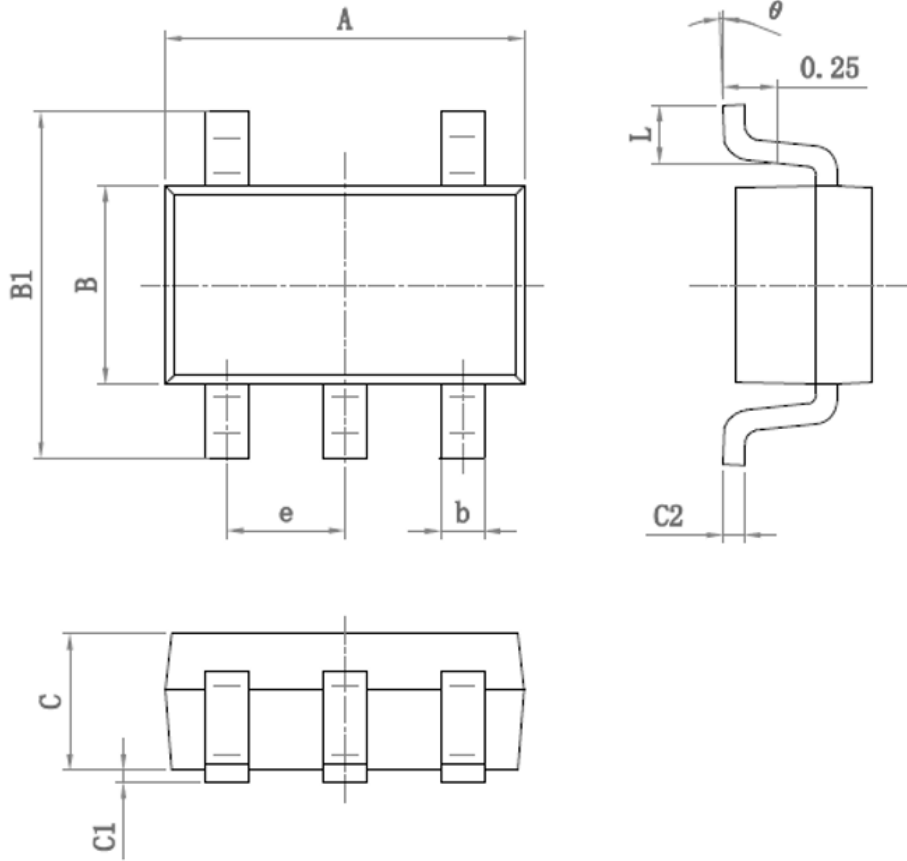

Symbol	Dimensions (mm)		Symbol	Dimensions (mm)	
	Min	Max		Min	Max
A	2.82	3.02	C	1.05	1.15
e	0.95 (BSC)		C1	0.03	0.15
b	0.28	0.45	C2	0.12	0.23
B	1.50	1.70	L	0.35	0.55
B1	2.60	3.00	θ	0°	8°