

## 300mA Low-IQ High PSRR Low-Dropout Voltage Regulator

### Features

- Input Voltage Range: 2.5V to 6.5V
- Output Voltage Range:
  - Fixed Operation: 1.8V to 5.0V
  - Adjustable Operation: 1.2V to 5.5V
- Maximum output current: 300mA
- Low Dropout Voltage: 152mV at 300mA
- Low Quiescent Current
- Low noise:  $45\mu V_{RMS}$
- Output Voltage Accuracy: 2%
- Excellent Load and Line Transient Responses
- Thermal Shutdown and Over-Current Protection
- Stable with  $1\mu F$  or Larger Ceramic Capacitor
- Operating Junction Temperature:  $-40^{\circ}C$  to  $+125^{\circ}C$
- Available package: SOT23-5

### Description

The device is a fast transient, high PSRR, low quiescent current (IQ) and low dropout voltage linear regulator capable of sourcing 300mA current. The low 152mV dropout voltage at 300mA load improves efficiency and allows operation over a wide input voltage range. The low 155uA of operating supply current at 300mA load makes the device suitable for battery-operated portable equipment.

The device also features soft-start to reduce inrush current, short-circuit current limit and thermal shutdown protection, as well as automatic discharge function to quickly discharge  $V_{OUT}$  in the disabled states.

### Applications

- Cellular Phones
- Laptop computers
- Portable Equipment
- Battery-Powered Systems
- High-Efficiency Linear Power Supplies

### Typical Application Circuits

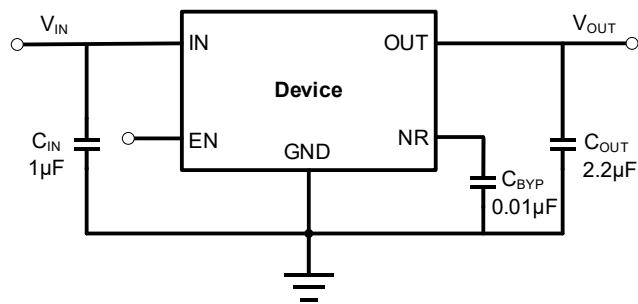

Fixed Output Voltage

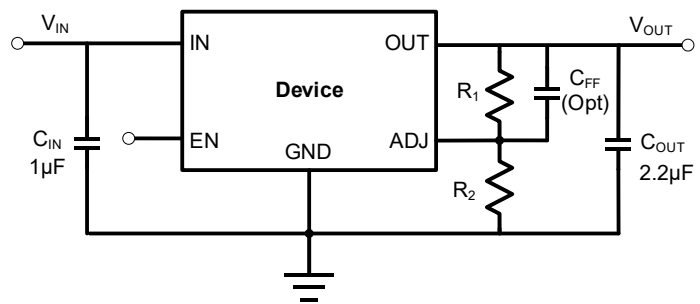

Adjustable Output Voltage

Pin Configuration and Functions

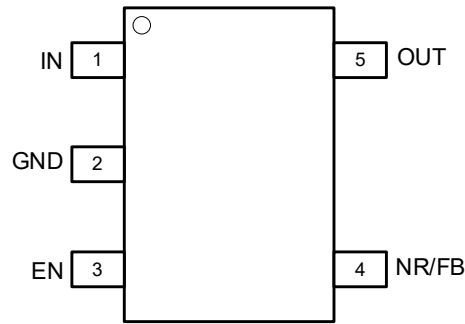

5-Pin SOT-23 (Top View)

Pin Descriptions

PIN Number	PIN Name	I/O	Function
1	IN	I	Input supply voltage pin. It is recommended to use a 1 $\mu$ F or larger ceramic capacitor from IN pin to ground to get a good power supply decoupling.
2	GND	-	Ground.
3	EN	I	Enable Pin. Drive EN high to turn on the regulator. Drive EN low to turn off the regulator.
4	NR/FB	-	For fixed voltage versions (NR), connect this pin to an external bypass capacitor to reduce the output noise. This pin can also be left open if low noise output is not required. For adjustable voltage version (FB), this pin is the input to the control loop error amplifier and sets the output voltage of the device.
5	OUT	O	Regulator output voltage pin. A 2.2 $\mu$ F or larger ceramic capacitor from OUT to ground is required to ensure regulator stability.

Ordering Information

DEVICE	PACKAGE TYPE	OUTPUT VOLTAGE	PACKING OPTION
TPS78418DBVR	SOT23-5	1.8V	Tape and Reel, 3000
TPS78425DBVR	SOT23-5	2.5V	Tape and Reel, 3000
TPS78433DBVR	SOT23-5	3.3V	Tape and Reel, 3000
TPS78450DBVR	SOT23-5	5.0V	Tape and Reel, 3000
TPS78401DBVR	SOT23-5	ADJ	Tape and Reel, 3000

## Electrical Specifications

### Absolute Maximum Ratings

Parameter	Symbol	Value	Unit
IN, OUT and EN Pins	IN, OUT and EN	-0.3 to 7	V
Storage temperature range	T <sub>STG</sub>	-65 to +150	°C
Output current	I <sub>OUT</sub>	Internally Limited	mA

#### Notes:

1. Exposure of the device under conditions beyond the limits specified by Maximum Ratings for extended periods may cause permanent damage to the device and affect product reliability. These conditions represent a stress rating only, and functional operations of the device at these or any other conditions above the operational limits noted in this specification is not implied.

### ESD Ratings

		Value	Unit
V <sub>ESD</sub>	Electrostatic Discharge	HBM (Human Body Model)	3000
		CDM (Charge Device Model)	1000

### Recommended Operation Conditions

Over operating temperature range unless otherwise noted

Parameter	Symbol	Min	Max	Unit
Input Supply Voltage	V <sub>IN</sub>	2.5	6.5	V
Enable Input Voltage	EN	0	V <sub>IN</sub>	V
Output Voltage	V <sub>OUT</sub>	1.2	4.5	V
Output Capacitance	C <sub>OUT</sub>	1	47	μF
Output Current	I <sub>OUT</sub>	0	500	mA
Operating Junction Temperature	T <sub>J</sub>	-40	125	°C

### Thermal Information

Package	R <sub>θJA</sub>	Unit
SOT23-5	205	°C/W

## Electrical Characteristics

$V_{IN} = 2.5V$  or  $V_{IN} = V_{OUT} + 1V$  (whichever is greater),  $I_{OUT} = 1mA$ ,  $C_{OUT} = 2.2\mu F$ , typical values are at  $T_A = 25^\circ C$  unless otherwise noted

Parameter	Symbol	Test Conditions	Min	Typ	Max	Unit
Input Voltage	$V_{IN}$		2.5	-	6.5	V
Output Voltage Accuracy		$0.1mA \leq I_{OUT} \leq 300mA$	-2.0	0	2.0	%
GND Pin Current	$I_{GND}$	$V_{IN} = 2.5V$ , No Load		82		$\mu A$
		$V_{IN} = 2.5V$ , $I_{OUT} = 300mA$		158		$\mu A$
Shutdown Current	$I_{SHDN}$	$V_{IN} = 2.5V$ , $V_{EN} = 0V$		2.3		$\mu A$
Dropout Voltage	$V_{DO}$	$V_{OUT} = 3.3V$ , $I_{OUT} = 300mA$		275		mV
Output Current Limit	$I_{LIM}$	$V_{OUT} = 0V$	500			mA
Line Regulation	$\Delta V_{OUT(LINE)}$	$V_{IN} = V_{OUT} + 1V$ to 6.5V		0.05		mV/V
Load Regulation	$\frac{\Delta V_{OUT}}{(V_{OUT} \Delta I_{OUT})}$	$V_{IN} = 6V$ , $I_{OUT} = 1mA$ to 300mA		0.3		%/A
EN pin low-level input voltage (device disabled)	$V_{IL(EN)}$				0.5	V
EN pin high-level input voltage (device enabled)	$V_{IH(EN)}$		1.6			V
EN PIN Leakage Current	$I_{EN}$	$V_{EN} = 6.5V$		0.8		$\mu A$
Power Supply Ripple Rejection	PSRR	$f = 1kHz$ , $V_{OUT} = 3.3V$ , $I_{OUT} = 300mA$		64		dB
Output Noise Voltage	$V_N$	BW = 10Hz to 100kHz, $C_{BYP} = 10nF$ , $C_{OUT} = 2.2\mu F$ , $V_{OUT} = 1.8V$ , $I_{OUT} = 300mA$		45		$\mu V$
Thermal Shutdown Temperature	TSD			160		$^\circ C$
Thermal Shutdown Hysteresis	$T_{HYS}$			20		$^\circ C$

## Typical Characteristics

$C_{IN} = 1\mu F$ ,  $C_{OUT} = 2.2\mu F$ ,  $I_{OUT} = 300mA$ ,  $T_A = 25^\circ C$  unless otherwise noted

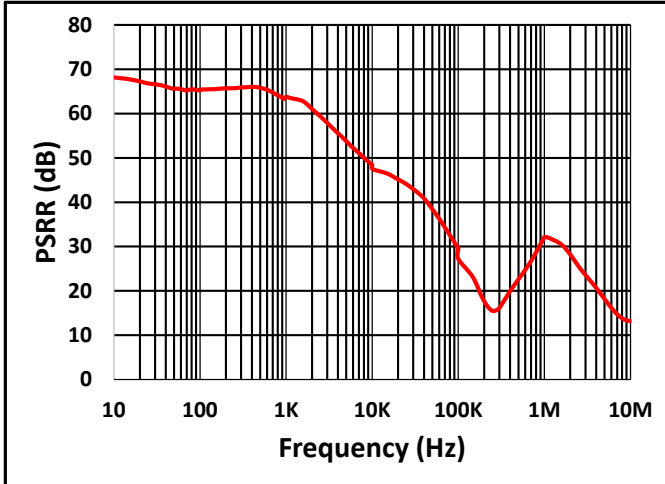

$V_{IN} = 6V$ ,  $V_{OUT} = 3.3V$ ,  $I_{OUT} = 300mA$ ,  $C_{OUT} = 2.2\mu F$

**Fig. 1 PSRR**

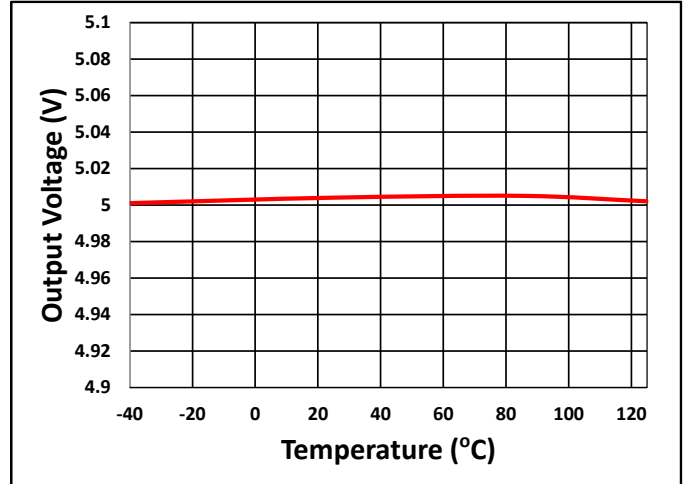

$V_{IN} = 6V$ ,  $V_{OUT} = 5V$ ,  $I_{OUT} = 0.1mA$

**Fig. 2 Output Voltage vs Temperature**

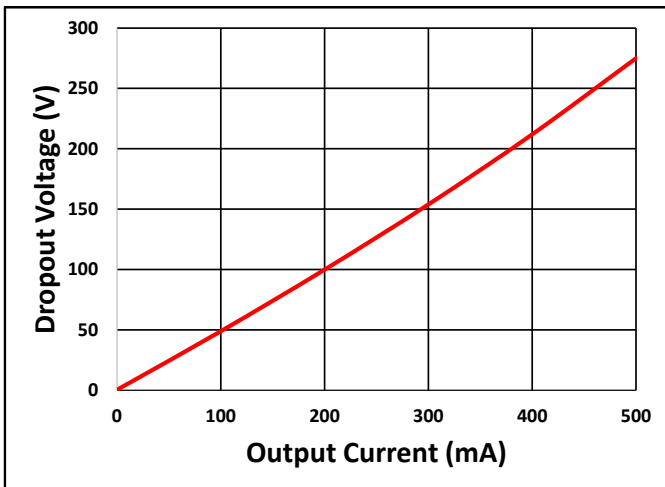

$V_{IN} = 6V$

**Fig. 3 Dropout Voltage**

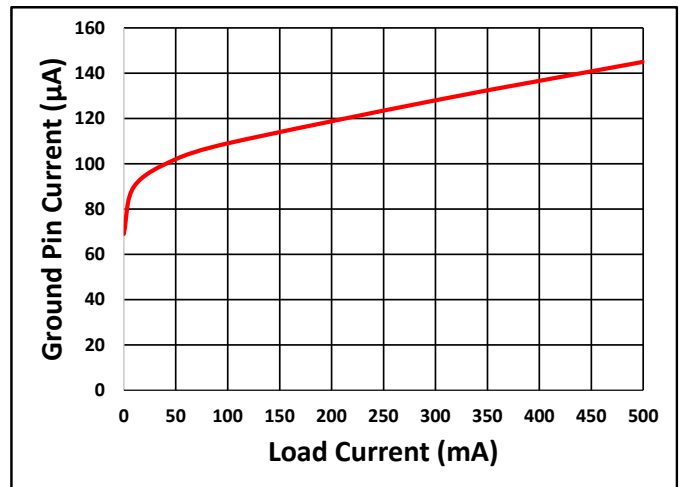

$V_{IN} = 2.5V$

**Fig. 4 Ground Current vs Load Current**

## Functional Block Diagram

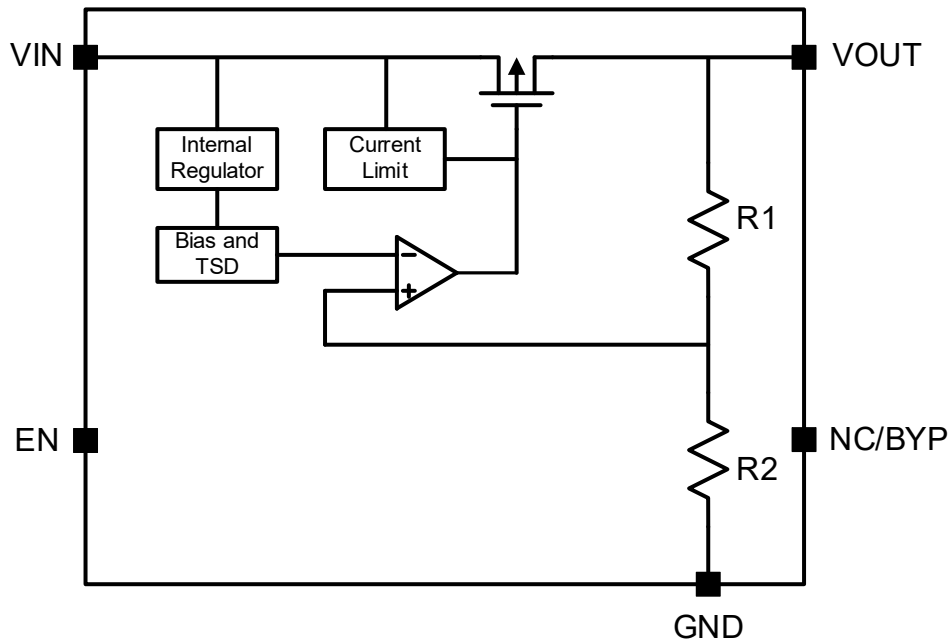

## Feature Description

**Enable**

The enable pin for the LDO is active high. The device is enabled when the enable pin voltage is greater than  $V_{IH(EN)}$  and disabled with the enable pin voltage less than  $V_{IL(EN)}$ . If independent control of chip enable is not needed, then connect the enable pin to the input. The LDO has an internal pulldown MOSFET that connects a discharge resistor from VOUT to ground when the device is disabled to actively discharge the output voltage.

**Output Current Limit**

When overload events happen, the output current is internally limited.

**Undervoltage Lockout (UVLO)**

The LDO uses an undervoltage lockout circuit to keep the output shut off until the internal circuitry is operating properly.

**Thermal Protection**

The LDO contains a thermal shutdown protection circuit to turn off the output current when excessive heat is dissipated in the LDO.

## Application Information

### Typical Application for Fixed and Adjustable Output Voltage

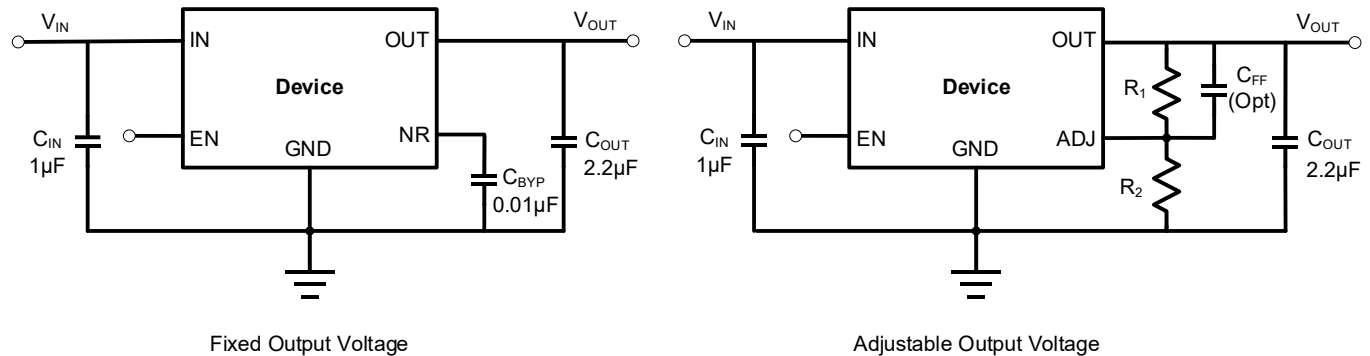

### Input Capacitor and Output Capacitor

The LDO is designed and characterized for operation with ceramic capacitors of 1 µF or greater at the input and 1 µF or greater at the output. Locate the input and output capacitors as near as practical to the input and output pins to minimize the trace inductance from the capacitor to the device.

### Adjustable Output Voltage

The output voltage of the LDO can be adjusted from 1.2V to 18V according to the following equation.

$$V_{OUT} = 1.2V \times \left(1 + \frac{R1}{R2}\right)$$

### Feed Forward Capacitor

A Feed-Forward Capacitor ( $C_{FF}$ ) in parallel with the R1 resistor as shown in the Figure above can be used to improve the output noise and PSRR performance. This  $C_{FF}$  is user optional for performance improvements not for LDO stability.

PACKAGE OUTLINE DIMENSIONS

SOT23-5

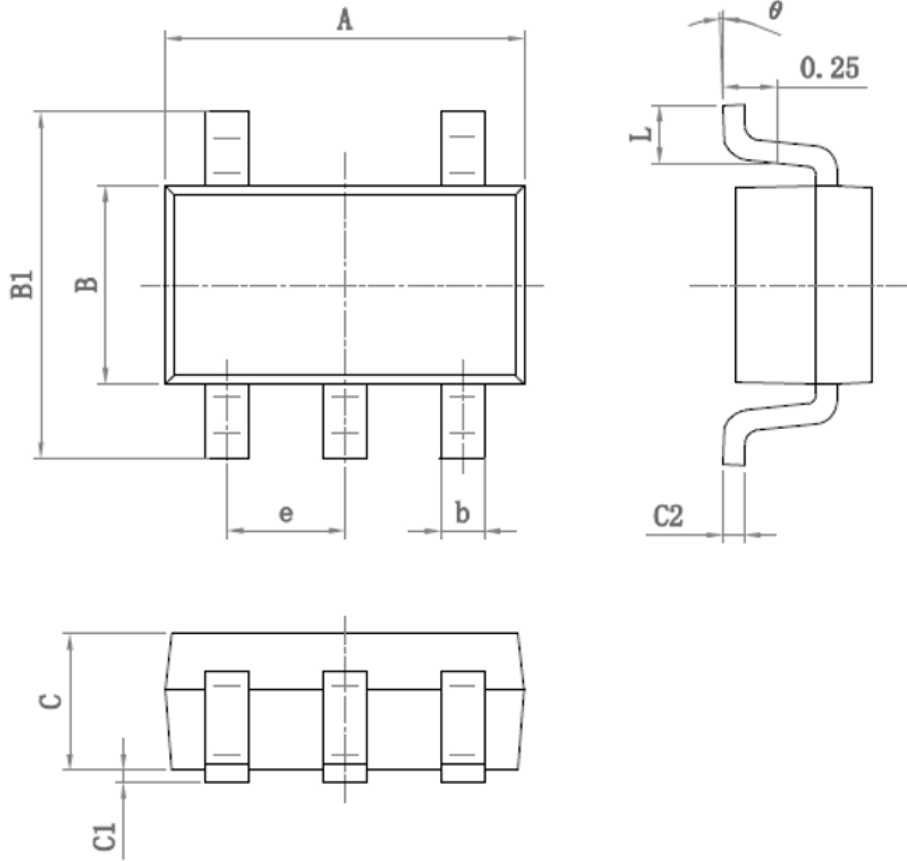

Symbol	Dimensions (mm)		Symbol	Dimensions (mm)	
	Min	Max		Min	Max
A	2.82	3.02	C	1.05	1.15
e	0.95 (BSC)		C1	0.03	0.15
b	0.28	0.45	C2	0.12	0.23
B	1.50	1.70	L	0.35	0.55
B1	2.60	3.00	θ	0°	8°