

1A 20V Low Dropout Linear Regulator

Features

- Very Low Dropout Voltage: 580mV at 1A
- Ultra-Low Quiescent Current: 128 μ A Typical
- Wide Input Voltage Range: 2.5V to 20V
- Output Voltage Range:
 - Fixed Operation: 1.8V, 2.5V, 3.3V, 5V
- Maximum output current: 1A
- Output Voltage Accuracy: 2%
- No Minimum Load Requirement
- Fast Load and Line Transient Responses
- Thermal Shutdown and Over-Current Protection
- Stable with 2.2 μ F or Larger Ceramic Capacitor
- Operating Junction Temperature: -40°C to +125°C
- Available packages: SOT-223, TO-252

Description

The NCV1117 is a very low dropout voltage, ultra-low quiescent current, high voltage, high PSRR linear regulator. The device provides fixed output voltages of 1.8V, 2.5V, 3.3V and 5V.

The NCV1117 also features over current limit and thermal shutdown protection, as well as automatic discharge function to quickly discharge V_{OUT} in the disabled states.

Applications

- Post Regulator for Switching DC-DC Converter
- Battery Chargers
- Portable Equipment
- High-Efficiency Linear Regulators

Typical Application Circuits

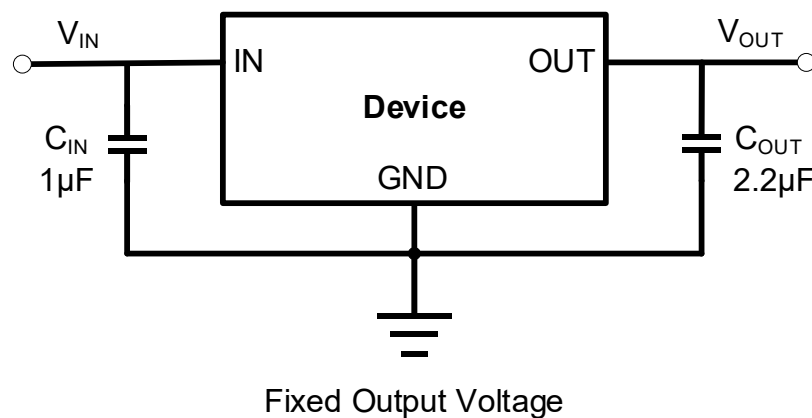

Pin Configuration and Functions

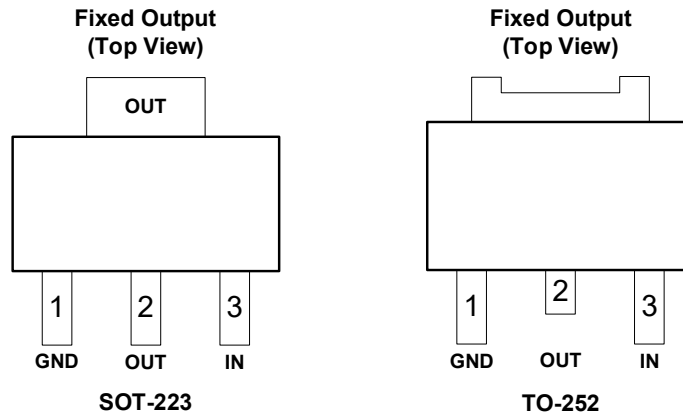

Pin Descriptions

PIN Number	PIN Name	I/O	Function
1	GND	-	Ground.
2	OUT	O	Regulator output voltage pin. A 2.2μF or larger ceramic capacitor from OUT to ground is required to ensure regulator stability. The capacitor should be placed as close to the output as possible. Minimize the impedance from the OUT pin to the load.
3	IN	I	Input supply voltage pin. It is recommended to use a 1μF or larger ceramic capacitor from IN pin to ground to get a good power supply decoupling.

Package/Ordering Information

DEVICE	PACKAGE TYPE	OUTPUT VOLTAGE	PACKING OPTION
NCV1117ST18T3G	SOT-223	1.8V	Tape and Reel, 1000
NCV1117ST25T3G	SOT-223	2.5V	Tape and Reel, 1000
NCV1117ST33T3G	SOT-223	3.3V	Tape and Reel, 1000
NCV1117ST50T3G	SOT-223	5.0V	Tape and Reel, 1000
NCV1117DT18RKG	TO-252	1.8V	Tape and Reel, 1000
NCV1117DT25RKG	TO-252	2.5V	Tape and Reel, 1000
NCV1117DT33RKG	TO-252	3.3V	Tape and Reel, 1000
NCV1117DT50RKG	TO-252	5.0V	Tape and Reel, 1000

Electrical Specifications

Absolute Maximum Ratings

Parameter	Symbol	Value	Unit
IN and OUT Pins	IN and OUT	-0.3 to 22	V
Storage temperature range	T _{STG}	-65 to +150	°C
Output current	I _{OUT}	Internally Limited	A

Notes:

1. Exposure of the device under conditions beyond the limits specified by Maximum Ratings for extended periods may cause permanent damage to the device and affect product reliability. These conditions represent a stress rating only, and functional operations of the device at these or any other conditions above the operational limits noted in this specification is not implied.

ESD Ratings

		Value	Unit
V _{ESD}	Electrostatic Discharge	HBM (Human Body Model)	3000
		CDM (Charge Device Model)	1000

Recommended Operation Conditions

Over operating temperature range unless otherwise noted

Parameter	Symbol	Min	Max	Unit
Input Supply Voltage	V _{IN}	2.5	20	V
Output Voltage	V _{OUT}	1.8	5	V
Output Capacitance	C _{OUT}	2.2	47	μF
Output Current	I _{OUT}	0	1	A
Operating Junction Temperature	T _J	-40	125	°C

Thermal Information

Package	R _{θJA}	Unit
SOT-223	95	°C/W
TO-252	70	°C/W

Electrical Characteristics

$V_{IN} = 2.5V$ or $V_{IN} = V_{OUT} + 1V$ (whichever is greater), $I_{OUT} = 1mA$, $C_{OUT} = 2.2\mu F$, typical values are at $T_A = 25^\circ C$ unless otherwise noted

Parameter	Symbol	Test Conditions	Min	Typ	Max	Unit
Input Voltage	V_{IN}		2.5	-	20	V
Output Voltage Accuracy		$0.1mA \leq I_{OUT} \leq 1A$	-2.0	0	2.0	%
GND Pin Current	I_{GND}	$V_{IN} = 20V$, No Load		128		μA
		$V_{IN} = 20V$, $I_{OUT} = 1A$		220		μA
Dropout Voltage	V_{DO}	$V_{OUT} = 3.3V$, $I_{OUT} = 1A$		580		mV
Output Current Limit	I_{LIM}	$V_{OUT} = 0$		1.6		A
Line Regulation	$\Delta V_{OUT(LINE)}$	$V_{IN} = (V_{OUT} + 1V)$ to 20V		1		mV
Load Regulation	$\frac{\Delta V_{OUT}}{\Delta I_{OUT}}$	$V_{IN} = 6V$, $I_{OUT} = 1mA$ to 1A		0.2		%/A
EN pin low-level input voltage (device disabled)	$V_{IL(EN)}$				0.5	V
EN pin high-level input voltage (device enabled)	$V_{IH(EN)}$		1.6			V
EN PIN Leakage Current	I_{EN}	$V_{EN} = 20V$		0.8		μA
Power Supply Ripple Rejection	PSRR	$f = 1kHz$, $V_{OUT} = 5V$, $I_{OUT} = 1A$		64		dB
Thermal Shutdown Temperature	TSD			160		$^\circ C$
Thermal Shutdown Hysteresis	T_{HYS}			20		$^\circ C$

Typical Characteristics

$C_{IN} = 1\mu F$, $C_{OUT} = 2.2\mu F$, $I_{OUT} = 1A$, $T_A = 25^\circ C$ unless otherwise noted

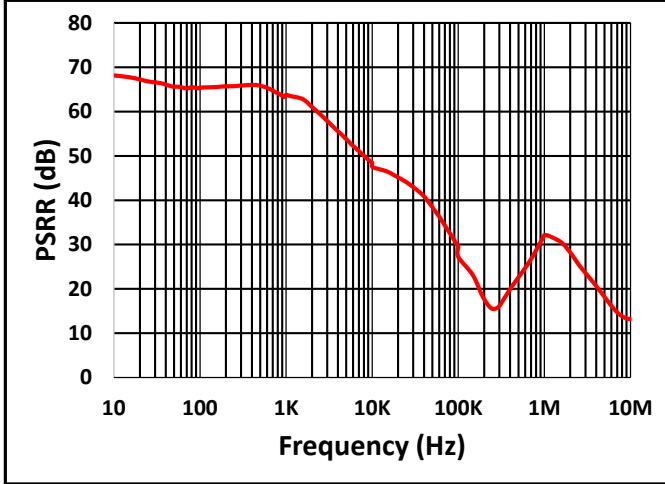

$V_{IN} = 6.5V$, $V_{OUT} = 5V$, $I_{OUT} = 500mA$, $C_{OUT} = 2.2\mu F$

Fig. 1 PSRR

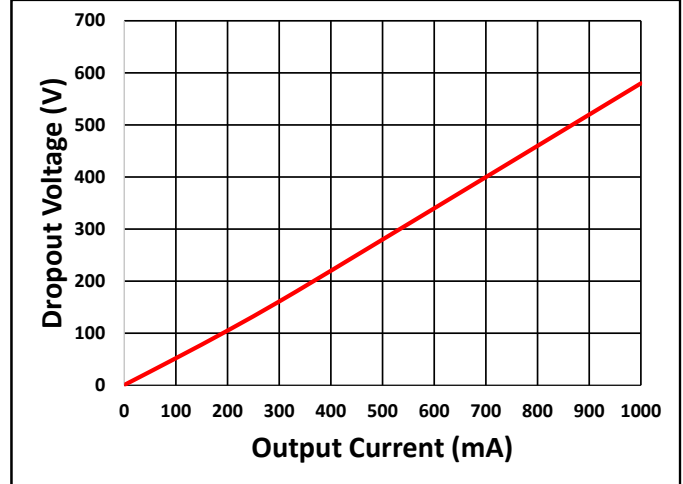

$V_{IN} = 6V$

Fig. 2 Dropout Voltage

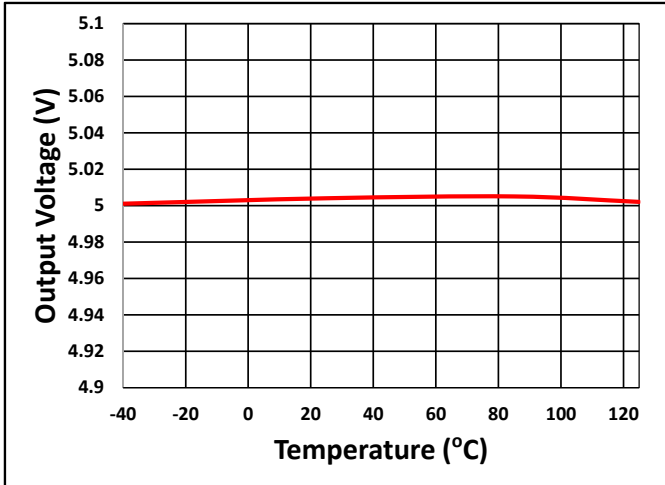

$V_{IN} = 6V$, $I_{OUT} = 0.1mA$

Fig. 3 Output Voltage vs Temperature

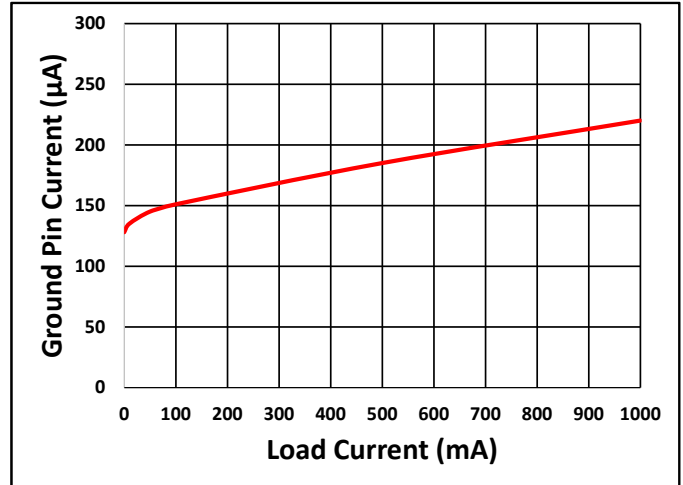

$V_{IN} = 20V$

Fig. 4 Ground Current vs Load Current

Functional Block Diagram

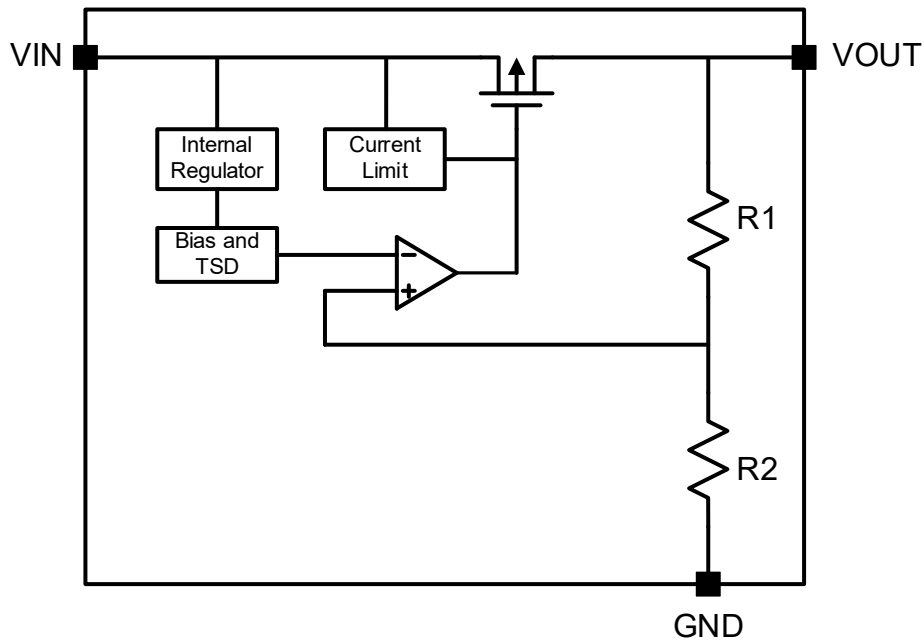

Block Diagram of Fixed Output Voltage

Feature Description

Dropout Voltage

Dropout voltage is defined as the input voltage minus the output voltage at the rated output current where the pass transistor is fully on. The pass transistor is in the ohmic or triode region of operation and acts as a switch. NCV1117 has a very low dropout voltage compared to most of the x1117 LDOs on the market.

Output Current Limit and Short-Circuit Protection

When overload events happen, the output current is internally limited.

Undervoltage Lockout (UVLO)

NCV1117 uses an undervoltage lockout circuit to keep the output shut off until the internal circuitry is operating properly.

Thermal Protection

NCV1117 contains a thermal shutdown protection circuit to turn off the output current when excessive heat is dissipated in the LDO.

PACKAGE OUTLINE DIMENSIONS

SOT-223

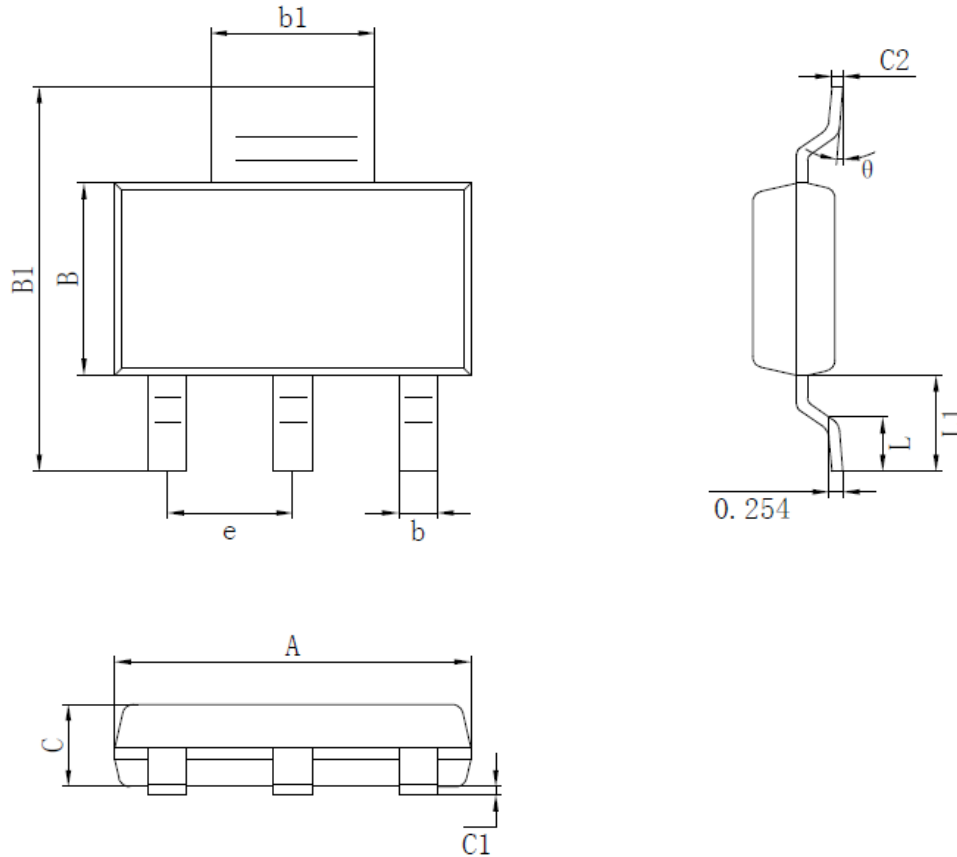

Symbol	Dimensions (mm)		Symbol	Dimensions (mm)	
	Min	Max		Min	Max
A	6.40	6.60	C	1.45	1.65
e	2.29 (BSC)		C1	0.03	0.15
b	0.66	0.76	C2	0.20	0.35
b1	2.95	3.05	L	0.76	1.16
B	3.40	3.60	L1	1.70	1.80
B1	6.85	7.15	theta	0°	8°

TO-252

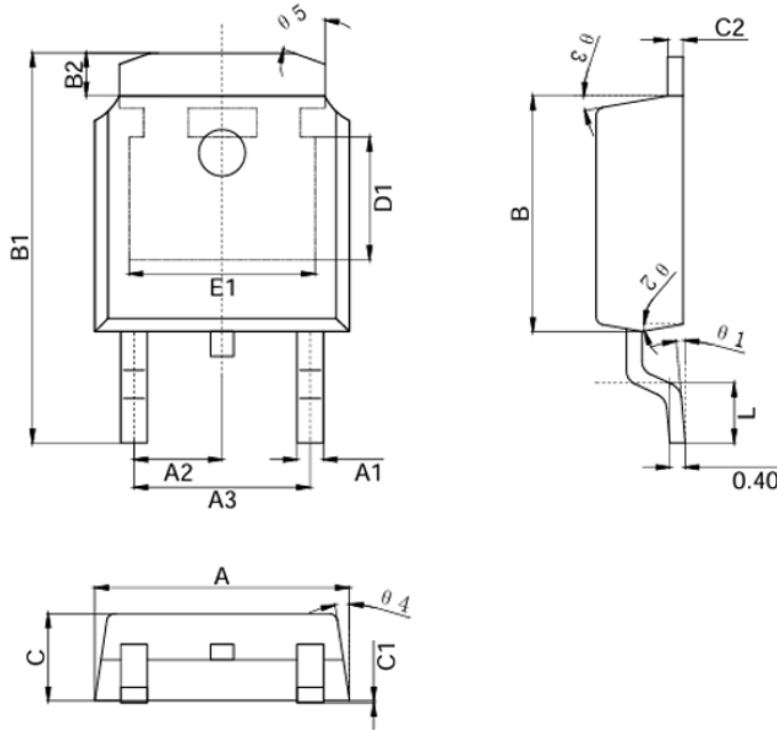

Symbol	Dimensions (mm)		Symbol	Dimensions (mm)	
	Min	Max		Min	Max
A	6.50	6.70	C2	0.375	0.45
A1	0.64	0.74	L	1.45	1.65
A2	2.286 TYP		D1	3.166 REF	
A3	4.572 TYP		E1	4.826 REF	
B	6.00	6.20	Θ1	0° ~ 8°	
B1	9.95	10.25	Θ2	10° TYP2	
B2	1.06	1.16	Θ3	10° TYP	
C	2.15	2.35	Θ4	8.5° TYP4	
C1	0.00	0.10	Θ5	70° TYP	